

Chapter 6

The Transport Layer

The Transport Service

- Services Provided to the Upper Layers
- Transport Service Primitives
- Berkeley Sockets
- An Example of Socket Programming:
 - An Internet File Server

Services Provided to the Upper Layers

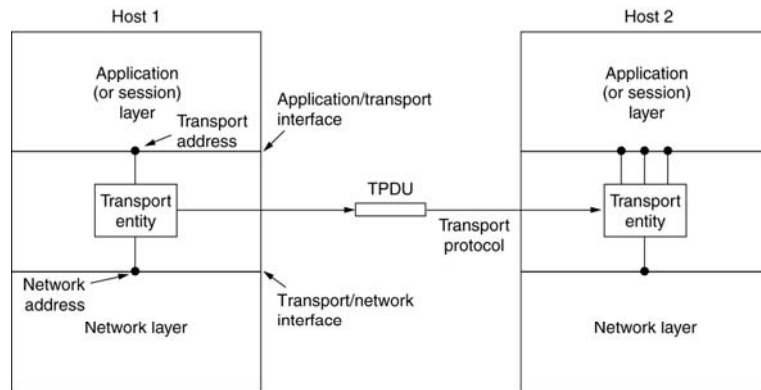

The network, transport, and application layers.

Transport Service Primitives

Primitive	Packet sent	Meaning
LISTEN	(none)	Block until some process tries to connect
CONNECT	CONNECTION REQ.	Actively attempt to establish a connection
SEND	DATA	Send information
RECEIVE	(none)	Block until a DATA packet arrives
DISCONNECT	DISCONNECTION REQ.	This side wants to release the connection

The primitives for a simple transport service.

Transport Service Primitives (2)

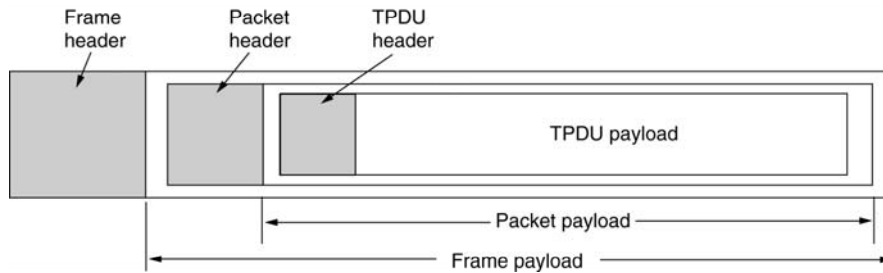

The nesting of TPDU, packets, and frames.

Transport Service Primitives (3)

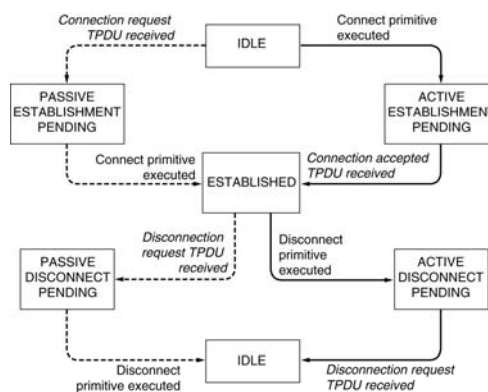

A state diagram for a simple connection management scheme. Transitions labeled in italics are caused by packet arrivals. The solid lines show the client's state sequence. The dashed lines show the server's state sequence.

Berkeley Sockets

Primitive	Meaning
SOCKET	Create a new communication end point
BIND	Attach a local address to a socket
LISTEN	Announce willingness to accept connections; give queue size
ACCEPT	Block the caller until a connection attempt arrives
CONNECT	Actively attempt to establish a connection
SEND	Send some data over the connection
RECEIVE	Receive some data from the connection
CLOSE	Release the connection

The socket primitives for TCP.

Socket Programming Example: Internet File Server

Client code using
sockets.

```

/* This page contains a client program that can request a file from the server program
 * on the next page. The server responds by sending the whole file.
 */
#include <sys/types.h>
#include <sys/socket.h>
#include <netinet/in.h>
#include <netdb.h>

#define SERVER_PORT 12345          /* arbitrary, but client & server must agree */
#define BUF_SIZE 4096            /* block transfer size */

int main(int argc, char **argv)
{
    int c, s, bytes;
    char buf[BUF_SIZE];           /* buffer for incoming file */
    struct hostent *h;            /* info about server */
    struct sockaddr_in channel;   /* holds IP address */

    if (argc != 3) fatal("Usage: client server-name file-name");
    h = gethostbyname(argv[1]);   /* look up host's IP address */
    if (!h) fatal("gethostbyname failed");

    s = socket(PF_INET, SOCK_STREAM, IPPROTO_TCP);
    if (s < 0) fatal("socket");
    memset(&channel, 0, sizeof(channel));
    channel.sin_family = AF_INET;
    memcpy(&channel.sin_addr.s_addr, argv[2], sizeof(channel.sin_addr.s_addr));
    channel.sin_port = htons(SERVER_PORT);

    c = connect(s, (struct sockaddr *) &channel, sizeof(channel));
    if (c < 0) fatal("connect failed");
    /* Connection is now established. Send file name including 0 byte at end. */
    write(s, argv[2], strlen(argv[2])+1);

    /* Go get the file and write it to standard output. */
    while (1) {
        bytes = read(s, buf, BUF_SIZE); /* read from socket */
        if (bytes <= 0) exit(0);        /* check for end of file */
        write(1, buf, bytes);          /* write to standard output */
    }
}

fatal(char *string)
{
    printf("%s\n", string);
    exit(1);
}

```

Socket Programming Example: Internet File Server (2)

Client code using sockets.

```

#include <sys/types.h> /* This is the server code */
#include <sys/fcntl.h>
#include <sys/socket.h>
#include <netinet/in.h>
#include <netdb.h>
#define SERVER_PORT 12345 /* arbitrary, but client & server must agree */
#define BUF_SIZE 4096 /* block transfer size */
#define QUEUE_SIZE 10
int main(int argc, char *argv[])
{
    int s, b, l, fd, sa, bytes, on = 1;
    char buf[BUF_SIZE]; /* buffer for outgoing file */
    struct sockaddr_in channel; /* hold's IP address */

    /* Build address structure to bind to socket. */
    memset(&channel, 0, sizeof(channel)); /* zero channel */
    channel.sin_family = AF_INET;
    channel.sin_addr.s_addr = htonl(INADDR_ANY);
    channel.sin_port = htons(SERVER_PORT);

    /* Passive open. Wait for connection. */
    s = socket(AF_INET, SOCK_STREAM, IPPROTO_TCP); /* create socket */
    if (s < 0) fatal("socket failed");
    setsockopt(s, SOL_SOCKET, SO_REUSEADDR, (char *) &on, sizeof(on));
    b = bind(s, (struct sockaddr *) &channel, sizeof(channel));
    if (b < 0) fatal("bind failed");

    l = listen(s, QUEUE_SIZE); /* specify queue size */
    if (l < 0) fatal("listen failed");

    /* Socket is now set up and bound. Wait for connection and process it. */
    while (1) {
        sa = accept(s, 0, 0); /* block for connection request */
        if (sa < 0) fatal("accept failed");
        read(sa, buf, BUF_SIZE); /* read file name from socket */

        /* Get and return the file. */
        fd = open(buf, O_RDONLY); /* open the file to be sent back */
        if (fd < 0) fatal("open failed");

        while (1) {
            bytes = read(fd, buf, BUF_SIZE); /* read from file */
            if (bytes <= 0) break; /* check for end of file */
            write(sa, buf, bytes); /* write bytes to socket */
        }
        close(fd); /* close file */
        close(sa); /* close connection */
    }
}

```

Elements of Transport Protocols

- Addressing
- Connection Establishment
- Connection Release
- Flow Control and Buffering
- Multiplexing
- Crash Recovery

Transport Protocol

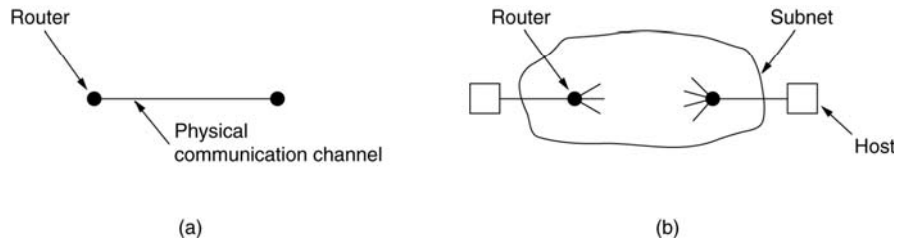

- (a) Environment of the data link layer.
- (b) Environment of the transport layer.

Addressing

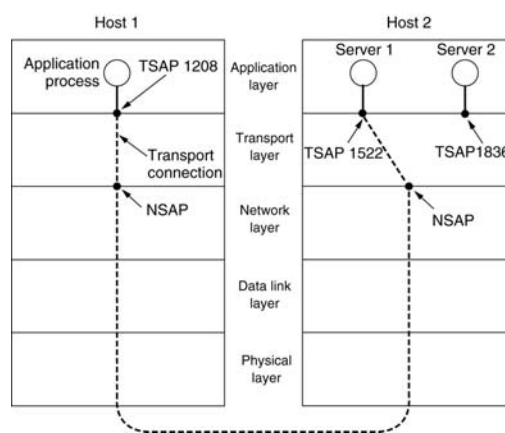

TSAPs, NSAPs and transport connections.

Connection Establishment

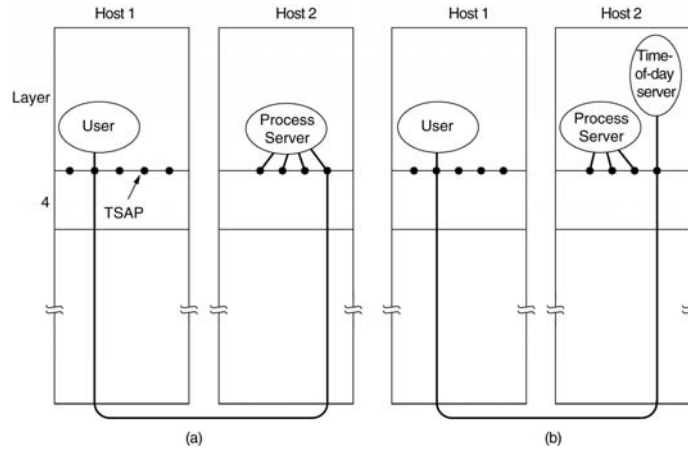

How a user process in host 1 establishes a connection with a time-of-day server in host 2.

Connection Establishment (2)

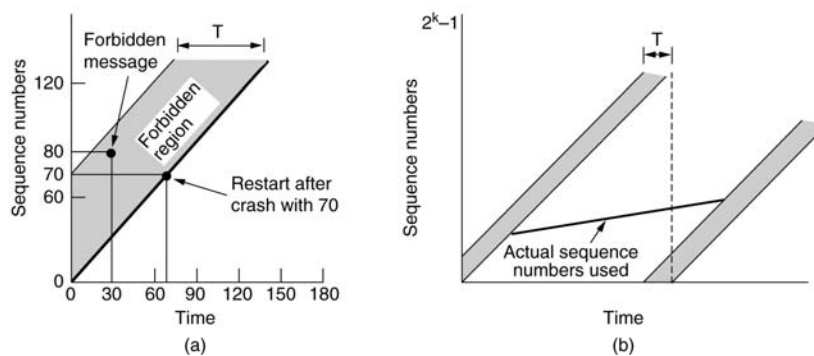

- (a) TPDU's may not enter the forbidden region.
- (b) The resynchronization problem.

Connection Establishment (3)

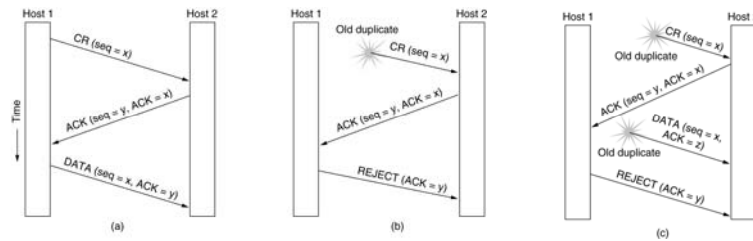

Connection Release

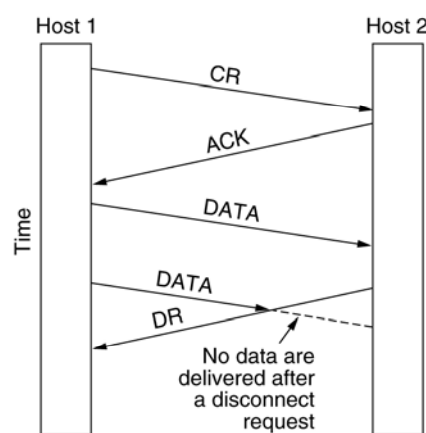

Abrupt disconnection with loss of data.

Connection Release (2)

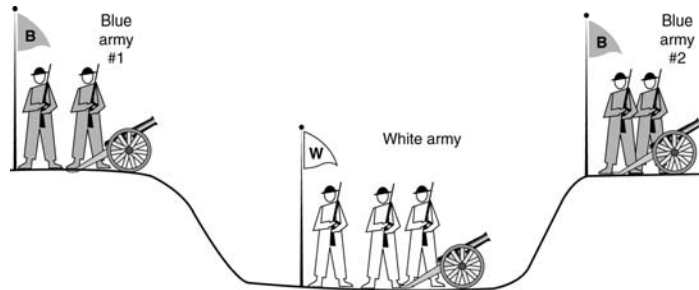

The two-army problem.

Connection Release (3)

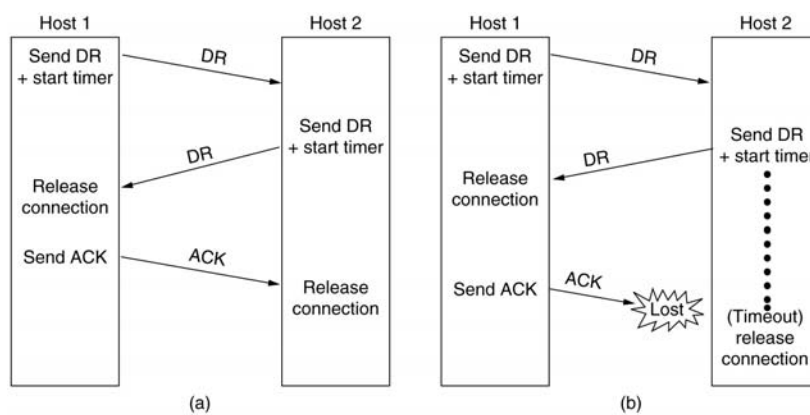

Four protocol scenarios for releasing a connection. (a) Normal case of a three-way handshake. (b) final ACK lost.

Connection Release (4)

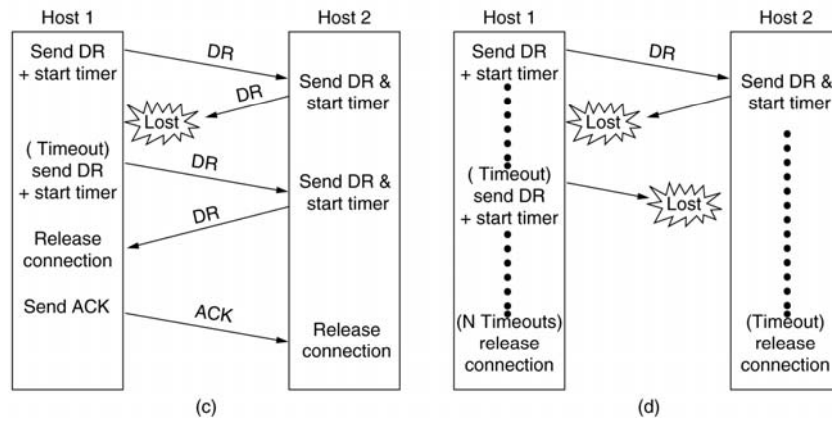

(c) Response lost. (d) Response lost and subsequent DRs lost.

Flow Control and Buffering

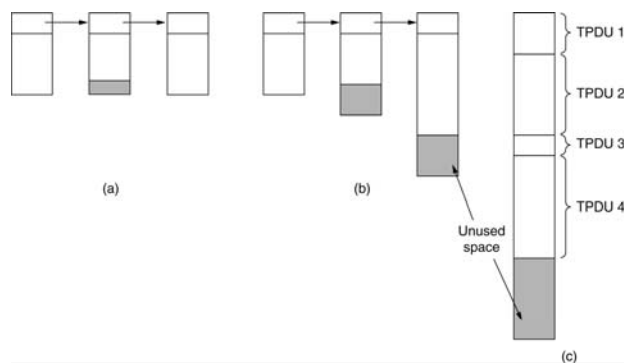

(a) Chained fixed-size buffers. (b) Chained variable-sized buffers.
 (c) One large circular buffer per connection.

Flow Control and Buffering (2)

A	Message	B	Comments
1 →	< request 8 buffers >	→	A wants 8 buffers
2 ←	<ack = 15, buf = 4 >	←	B grants messages 0-3 only
3 →	<seq = 0, data = m0 >	→	A has 3 buffers left now
4 →	<seq = 1, data = m1 >	→	A has 2 buffers left now
5 →	<seq = 2, data = m2 >	...	Message lost but A thinks it has 1 left
6 ←	<ack = 1, buf = 3 >	←	B acknowledges 0 and 1, permits 2-4
7 →	<seq = 3, data = m3 >	→	A has 1 buffer left
8 →	<seq = 4, data = m4 >	→	A has 0 buffers left, and must stop
9 →	<seq = 2, data = m2 >	→	A times out and retransmits
10 ←	<ack = 4, buf = 0 >	←	Everything acknowledged, but A still blocked
11 ←	<ack = 4, buf = 1 >	←	A may now send 5
12 ←	<ack = 4, buf = 2 >	←	B found a new buffer somewhere
13 →	<seq = 5, data = m5 >	→	A has 1 buffer left
14 →	<seq = 6, data = m6 >	→	A is now blocked again
15 ←	<ack = 6, buf = 0 >	←	A is still blocked
16 ...	<ack = 6, buf = 4 >	←	Potential deadlock

Dynamic buffer allocation. The arrows show the direction of transmission. An ellipsis (...) indicates a lost TPDU.

Multiplexing

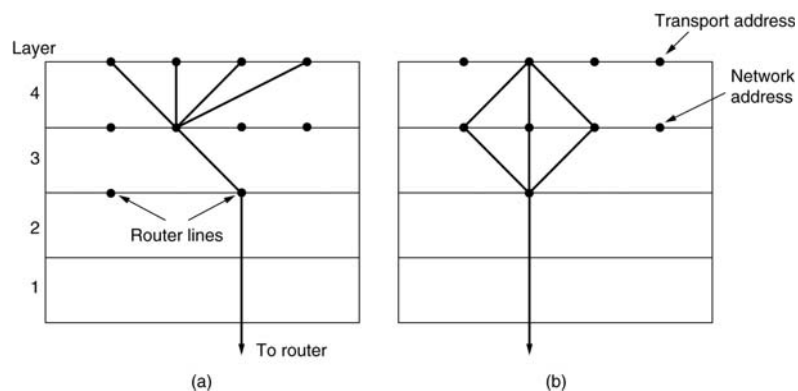

(a) Upward multiplexing. (b) Downward multiplexing.

A Simple Transport Protocol

- The Example Service Primitives
- The Example Transport Entity
- The Example as a Finite State Machine

The Example Transport Entity

Network packet	Meaning
CALL REQUEST	Sent to establish a connection
CALL ACCEPTED	Response to CALL REQUEST
CLEAR REQUEST	Sent to release a connection
CLEAR CONFIRMATION	Response to CLEAR REQUEST
DATA	Used to transport data
CREDIT	Control packet for managing the window

The network layer packets used in our example.

The Example Transport Entity (2)

Each connection is in one of seven states:

1. Idle – Connection not established yet.
2. Waiting – CONNECT has been executed, CALL REQUEST sent.
3. Queued – A CALL REQUEST has arrived; no LISTEN yet.
4. Established – The connection has been established.
5. Sending – The user is waiting for permission to send a packet.
6. Receiving – A RECEIVE has been done.
7. DISCONNECTING – a DISCONNECT has been done locally.

The Example Transport Entity (3)

```

#define MAX_CONN 32                /* max number of simultaneous connections */
#define MAX_MSG_SIZE 8192         /* largest message in bytes */
#define MAX_PKT_SIZE 512         /* largest packet in bytes */
#define TIMEOUT 20
#define CRED 1
#define OK 0

#define ERR_FULL -1
#define ERR_REJECT -2
#define ERR_CLOSED -3
#define LOW_ERR -3

typedef int transport_address;
typedef enum {CALL_REQ,CALL_ACC,CLEAR_REQ,CLEAR_CONF,DATA_PKT,CREDIT} pkt_type;
typedef enum {IDLE,WAITING,QUEUED,ESTABLISHED,SENDING,RECEIVING,DISCONN} cstate;

/* Global variables. */
transport_address listen_address; /* local address being listened to */
int listen_conn;                 /* connection identifier for listen */
unsigned char data[MAX_PKT_SIZE]; /* scratch area for packet data */

struct conn {
    transport_address local_address, remote_address;
    cstate state;                /* state of this connection */
    unsigned char *user_buf_addr; /* pointer to receive buffer */
    int byte_count;              /* send/receive count */
    int clr_req_received;        /* set when CLEAR_REQ packet received */
    int timer;                   /* used to time out CALL_REQ packets */
    int credits;                 /* number of messages that may be sent */
} conn[MAX_CONN + 1];           /* slot 0 is not used */

```

The Example Transport Entity (4)

```

void sleep(void);                /* prototypes */
void wakeup(void);
void to_net(int cid, int q, int m, pkt_type pt, unsigned char *p, int bytes);
void from_net(int *cid, int *q, int *m, pkt_type *pt, unsigned char *p, int *bytes);

int listen(transport_address t)
{ /* User wants to listen for a connection. See if CALL_REQ has already arrived. */
  int i, found = 0;

  for (i = 1; i <= MAX_CONN; i++) /* search the table for CALL_REQ */
    if (conn[i].state == QUEUED && conn[i].local_address == t) {
      found = i;
      break;
    }

  if (found == 0) {
    /* No CALL_REQ is waiting. Go to sleep until arrival or timeout. */
    listen_address = t; sleep(); i = listen_conn;
  }
  conn[i].state = ESTABLISHED; /* connection is ESTABLISHED */
  conn[i].timer = 0;          /* timer is not used */
}

```

The Example Transport Entity (5)

```

listen_conn = 0; /* 0 is assumed to be an invalid address */
to_net(i, 0, 0, CALL_ACC, data, 0); /* tell net to accept connection */
return(i); /* return connection identifier */
}

int connect(transport_address l, transport_address r)
{ /* User wants to connect to a remote process; send CALL_REQ packet. */
  int i;
  struct conn *cptr;

  data[0] = r; data[1] = l; /* CALL_REQ packet needs these */
  i = MAX_CONN; /* search table backward */
  while (conn[i].state != IDLE && i > 1) i = i - 1;
  if (conn[i].state == IDLE) {
    /* Make a table entry that CALL_REQ has been sent. */
    cptr = &conn[i];
    cptr->local_address = l; cptr->remote_address = r;
    cptr->state = WAITING; cptr->clr_req_received = 0;
    cptr->credits = 0; cptr->timer = 0;
    to_net(i, 0, 0, CALL_REQ, data, 2);
    sleep(); /* wait for CALL_ACC or CLEAR_REQ */
    if (cptr->state == ESTABLISHED) return(i);
    if (cptr->clr_req_received) {
      /* Other side refused call. */
      cptr->state = IDLE; /* back to IDLE state */
      to_net(i, 0, 0, CLEAR_CONF, data, 0);
      return(ERR_REJECT);
    }
  } else return(ERR_FULL); /* reject CONNECT: no table space */
}

```

The Example Transport Entity (6)

```

int send(int cid, unsigned char bufptr[], int bytes)
{ /* User wants to send a message. */
  int i, count, m;
  struct conn *cptr = &conn[cid];

  /* Enter SENDING state. */
  cptr->state = SENDING;
  cptr->byte_count = 0; /* # bytes sent so far this message */
  if (cptr->clr_req_received == 0 && cptr->credits == 0) sleep();
  if (cptr->clr_req_received == 0) {
    /* Credit available; split message into packets if need be. */
    do {
      if (bytes - cptr->byte_count > MAX_PKT_SIZE) { /* multipacket message */
        count = MAX_PKT_SIZE; m = 1; /* more packets later */
      } else { /* single packet message */
        count = bytes - cptr->byte_count; m = 0; /* last pkt of this message */
      }
      for (i = 0; i < count; i++) data[i] = bufptr[cptr->byte_count + i];
      to_net(cid, 0, m, DATA_PKT, data, count); /* send 1 packet */
      cptr->byte_count = cptr->byte_count + count; /* increment bytes sent so far */
    } while (cptr->byte_count < bytes); /* loop until whole message sent */
  }
}

```

The Example Transport Entity (7)

```

  cptr->credits --; /* each message uses up one credit */
  cptr->state = ESTABLISHED;
  return(OK);
} else {
  cptr->state = ESTABLISHED;
  return(ERR_CLOSED); /* send failed: peer wants to disconnect */
}
}

int receive(int cid, unsigned char bufptr[], int *bytes)
{ /* User is prepared to receive a message. */
  struct conn *cptr = &conn[cid];

  if (cptr->clr_req_received == 0) {
    /* Connection still established; try to receive. */
    cptr->state = RECEIVING;
    cptr->user_buf_addr = bufptr;
    cptr->byte_count = 0;
    data[0] = CRED;
    data[1] = 1;
    to_net(cid, 1, 0, CREDIT, data, 2); /* send credit */
    sleep(); /* block awaiting data */
    *bytes = cptr->byte_count;
  }
  cptr->state = ESTABLISHED;
  return(cptr->clr_req_received ? ERR_CLOSED : OK);
}

```

The Example Transport Entity (8)

```

int disconnect(int cid)
{ /* User wants to release a connection. */
  struct conn *cptr = &conn[cid];

  if (cptr->clr_req_received) { /* other side initiated termination */
    cptr->state = IDLE; /* connection is now released */
    to_net(cid, 0, 0, CLEAR_CONF, data, 0);
  } else { /* we initiated termination */
    cptr->state = DISCONN; /* not released until other side agrees */
    to_net(cid, 0, 0, CLEAR_REQ, data, 0);
  }
  return(OK);
}

void packet_arrival(void)
{ /* A packet has arrived, get and process it. */
  int cid; /* connection on which packet arrived */
  int count, i, q, m;
  pkt_type ptype; /* CALL_REQ, CALL_ACC, CLEAR_REQ, CLEAR_CONF, DATA_PKT, CREDIT */
  unsigned char data[MAX_PKT_SIZE]; /* data portion of the incoming packet */
  struct conn *cptr;

  from_net(&cid, &q, &m, &ptype, data, &count); /* go get it */
  cptr = &conn[cid];

```

The Example Transport Entity (9)

```

switch (ptype) {
case CALL_REQ: /* remote user wants to establish connection */
  cptr->local_address = data[0]; cptr->remote_address = data[1];
  if (cptr->local_address == listen_address) {
    listen_conn = cid; cptr->state = ESTABLISHED; wakeup();
  } else {
    cptr->state = QUEUED; cptr->timer = TIMEOUT;
  }
  cptr->clr_req_received = 0; cptr->credits = 0;
  break;
case CALL_ACC: /* remote user has accepted our CALL_REQ */
  cptr->state = ESTABLISHED;
  wakeup();
  break;
case CLEAR_REQ: /* remote user wants to disconnect or reject call */
  cptr->clr_req_received = 1;
  if (cptr->state == DISCONN) cptr->state = IDLE; /* clear collision */
  if (cptr->state == WAITING || cptr->state == RECEIVING || cptr->state == SENDING) wakeup();
  break;
case CLEAR_CONF: /* remote user agrees to disconnect */
  cptr->state = IDLE;
  break;
case CREDIT: /* remote user is waiting for data */
  cptr->credits += data[1];
  if (cptr->state == SENDING) wakeup();
  break;
case DATA_PKT: /* remote user has sent data */
  for (i = 0; i < count; i++) cptr->user_buf_addr[cptr->byte_count + i] = data[i];
  cptr->byte_count += count;
  if (m == 0) wakeup();
}
}

```



The Example Transport Entity (10)

```
}  
void clock(void)  
{ /* The clock has ticked, check for timeouts of queued connect requests. */  
  int i;  
  struct conn *cptr;  
  for (i = 1; i <= MAX_CONN; i++) {  
    cptr = &conn[i];  
    if (cptr->timer > 0) { /* timer was running */  
      cptr->timer--;  
      if (cptr->timer == 0) { /* timer has now expired */  
        cptr->state = IDLE;  
        to_net(i, 0, 0, CLEAR_REQ, data, 0);  
      }  
    }  
  }  
}
```

The Internet Transport Protocols: UDP

- Introduction to UDP
- Remote Procedure Call
- The Real-Time Transport Protocol

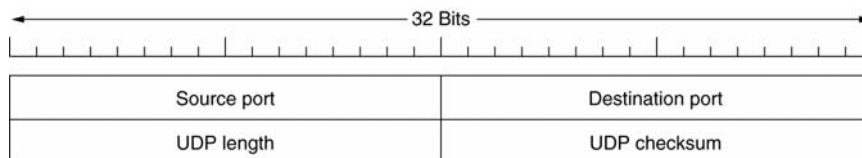
Introduction to UDP



The UDP header.

The Internet Transport Protocols: TCP

- Introduction to TCP
- The TCP Service Model
- The TCP Protocol
- The TCP Segment Header
- TCP Connection Establishment
- TCP Connection Release
- TCP Connection Management Modeling
- TCP Transmission Policy
- TCP Congestion Control
- TCP Timer Management
- Wireless TCP and UDP
- Transactional TCP

The TCP Service Model

Port	Protocol	Use
21	FTP	File transfer
23	Telnet	Remote login
25	SMTP	E-mail
69	TFTP	Trivial File Transfer Protocol
79	Finger	Lookup info about a user
80	HTTP	World Wide Web
110	POP-3	Remote e-mail access
119	NNTP	USENET news

Some assigned ports.

The TCP Service Model (2)

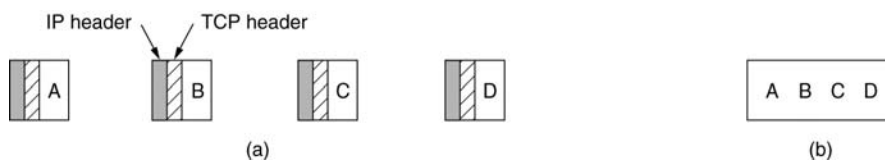

- (a) Four 512-byte segments sent as separate IP datagrams.
- (b) The 2048 bytes of data delivered to the application in a single READ CALL.

The TCP Segment Header

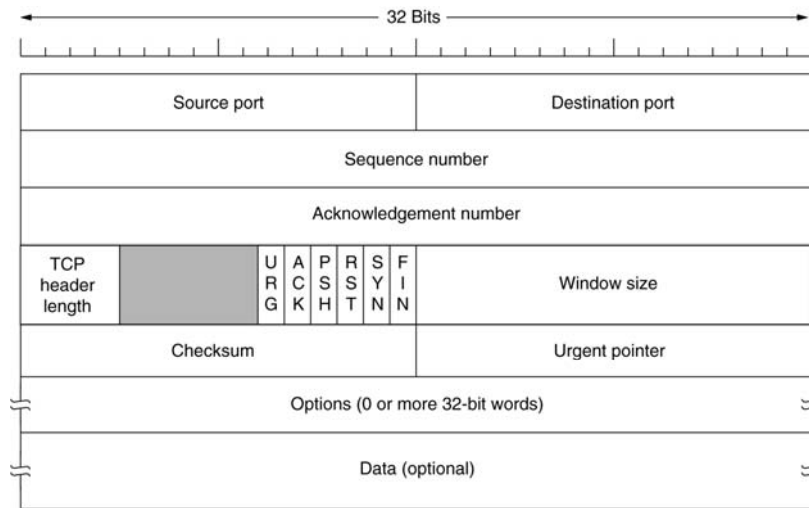

TCP Header.

The TCP Segment Header (2)

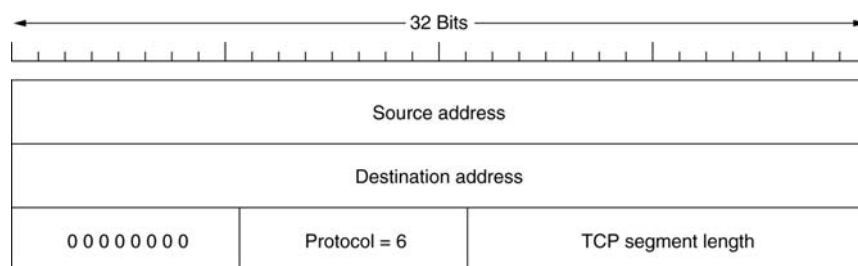

The pseudoheader included in the TCP checksum.

TCP Connection Establishment

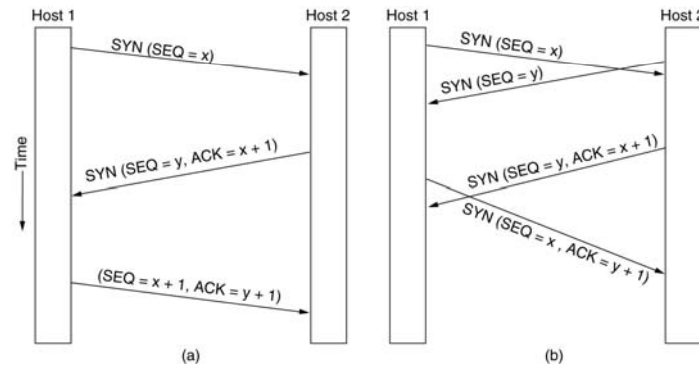

- (a) TCP connection establishment in the normal case.
 (b) Call collision.

TCP Connection Management Modeling

State	Description
CLOSED	No connection is active or pending
LISTEN	The server is waiting for an incoming call
SYN RCVD	A connection request has arrived; wait for ACK
SYN SENT	The application has started to open a connection
ESTABLISHED	The normal data transfer state
FIN WAIT 1	The application has said it is finished
FIN WAIT 2	The other side has agreed to release
TIMED WAIT	Wait for all packets to die off
CLOSING	Both sides have tried to close simultaneously
CLOSE WAIT	The other side has initiated a release
LAST ACK	Wait for all packets to die off

The states used in the TCP connection management finite state machine.

TCP Connection Management Modeling (2)

TCP connection management finite state machine. The heavy solid line is the normal path for a client. The heavy dashed line is the normal path for a server. The light lines are unusual events. Each transition is labeled by the event causing it and the action resulting from it, separated by a slash.

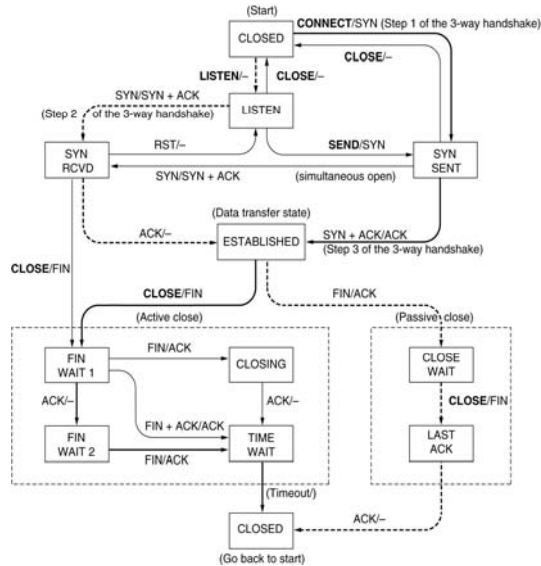

TCP Transmission Policy

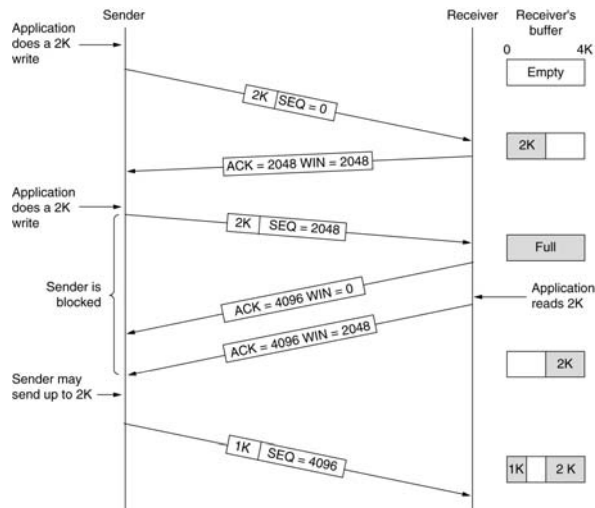

Window management in TCP.

TCP Transmission Policy (2)

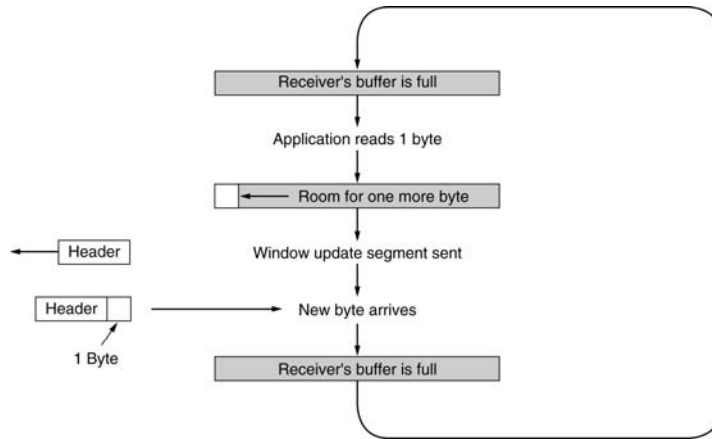

Silly window syndrome.

TCP Congestion Control

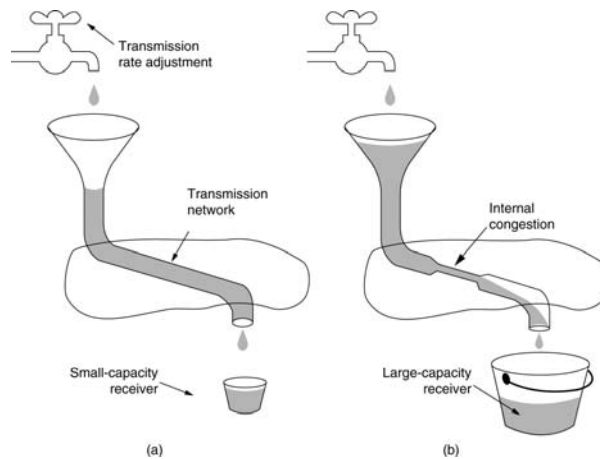

- (a) A fast network feeding a low capacity receiver.
- (b) A slow network feeding a high-capacity receiver.

TCP Congestion Control (2)

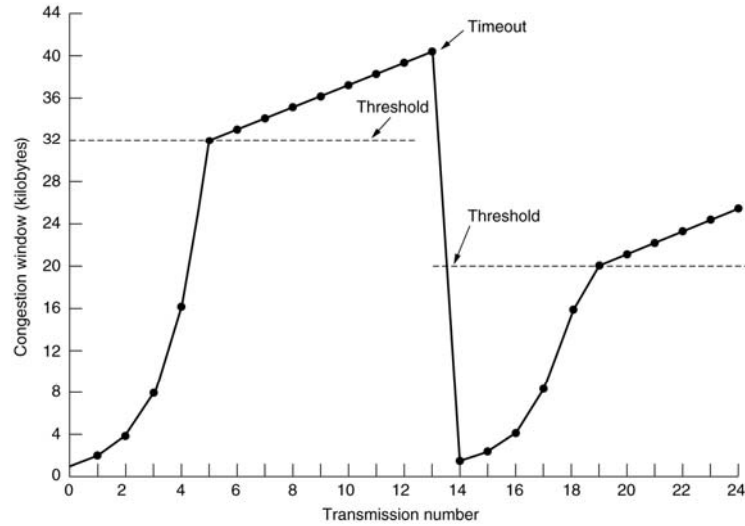

An example of the Internet congestion algorithm.

TCP Timer Management

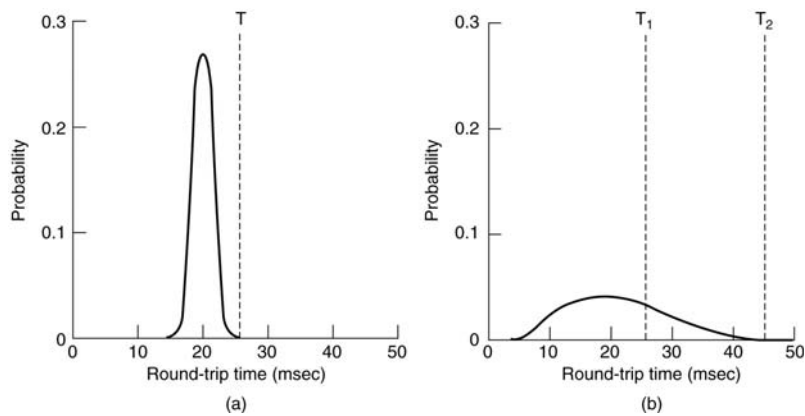

- (a) Probability density of ACK arrival times in the data link layer.
- (b) Probability density of ACK arrival times for TCP.

Wireless TCP and UDP

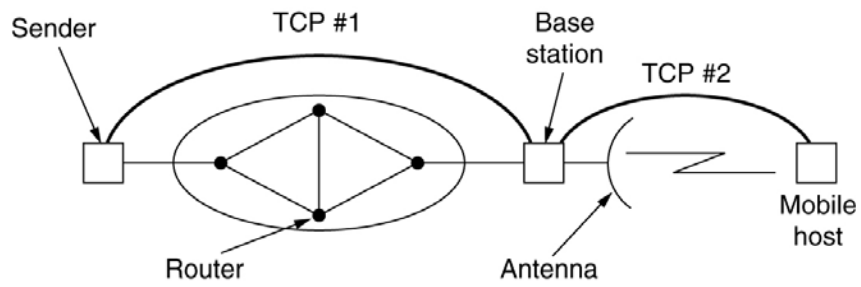

Splitting a TCP connection into two connections.