

Wavelets and filterbanks

Mallat 2009, Chapter 7

Outline

- Wavelets and Filterbanks
- Biorthogonal bases
- The dual perspective: from FB to wavelet bases
 - Biorthogonal FB
 - Perfect reconstruction conditions
- Separable bases (2D)
- Overcomplete bases
 - Wavelet frames (algorithme à trous, DDWF)
 - Curvelets

Wavelets and Filterbanks

Wavelet side

- **Scaling function**
 - Design (from multiresolution priors)
 - Signal approximation
 - Corresponding filtering operation
 - Condition on the filter $h[n]$ → Conjugate Mirror Filter (CMF)
- **Corresponding wavelet families**

Filterbank side

- **Perfect reconstruction conditions (PR)**
 - Reversibility of the transform
- **Equivalence with the conditions on the wavelet filters**
 - Special case: CMFs → Orthogonal wavelets
 - General case → Biorthogonal wavelets

Wavelets and filterbanks

- The decomposition coefficients in a wavelet orthogonal basis are computed with a fast algorithm that cascades discrete convolutions with h and g , and subsample the output
- Fast orthogonal WT

$$f(t) = \sum_n a_0[n] \varphi(t-n) \in V_0$$

Since $\{\varphi(t-n)\}_{n \in \mathbb{Z}}$ is an orthonormal basis

$$a_0[n] = \langle f(t), \varphi(t-n) \rangle = \int_{-\infty}^{+\infty} f(t) \varphi^*(t-n) dt = \int_{-\infty}^{+\infty} f(t) \bar{\varphi}^*(n-t) dt = f * \bar{\varphi}(n)$$

$$\bar{\varphi}(t) = \varphi(-t)$$

Linking the domains

$$z = e^{j\omega}$$

$$\hat{f}(\omega) = \hat{f}(e^{j\omega}) \leftrightarrow f(z)$$

$$\hat{f}(\omega + \pi) = \hat{f}(e^{j(\omega + \pi)}) = \hat{f}(-e^{j\omega}) \leftrightarrow f(-z)$$

$$\hat{f}(-\omega) = \hat{f}(e^{-j\omega}) \leftrightarrow f(z^{-1})$$

$$\hat{f}^*(\omega) = \hat{f}(-\omega) \leftrightarrow f(z^{-1})$$

Switching between the
Fourier and the z-domain

$$f[n] \leftrightarrow f(z) = \sum_{k=-\infty}^{+\infty} h[k]z^{-k}$$

$$f[n-1] \leftrightarrow z^{-1}f(z) \quad \text{unit delay}$$

$$f[-n] \leftrightarrow f(z^{-1}) \quad \text{reverse the order of the coefficients}$$

$$(-1)^n f[n] \leftrightarrow f(-z) \quad \text{negate odd terms}$$

Switching between the time
and the z-domain

Fast orthogonal wavelet transform

- Fast FB algorithm that computes the orthogonal wavelet coefficients of a discrete signal $a_0[n]$. Let us define

$$f(t) = \sum_n a_0[n] \varphi(t - n) \in V_0$$

Since $\{\varphi(t - n)\}_{n \in \mathbb{Z}}$ is orthonormal, then

$$a_0[n] = \langle f(t), \varphi(t - n) \rangle = f * \bar{\varphi}(n)$$

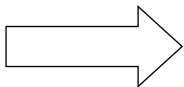

$$a_j[n] = \langle f, \varphi_{j,n} \rangle$$
 since $\varphi_{j,n}$ is an orthonormal basis for V_j

$$d_j[n] = \langle f, \psi_{j,n} \rangle$$

- A fast wavelet transform decomposes successively each approximation $PV_j f$ in the coarser approximation $PV_{j+1} f$ plus the wavelet coefficients carried by $PW_{j+1} f$.*
- In the reconstruction, $PV_j f$ is recovered from $PV_{j+1} f$ and $PW_{j+1} f$ for decreasing values of j starting from J (decomposition depth)*

Fast wavelet transform

- Theorem 7.7

- At the decomposition

$$a_{j+1}[p] = \sum_{n=-\infty}^{+\infty} h[n-2p]a_j[n] = a_j * \bar{h}[2p] \quad (1)$$

$$d_{j+1}[p] = \sum_{n=-\infty}^{+\infty} g[n-2p]a_j[n] = a_j * \bar{g}[2p] \quad (2)$$

- At the reconstruction

$$a_j[p] = \sum_{n=-\infty}^{+\infty} h[p-2n]a_{j+1}[n] + \sum_{n=-\infty}^{+\infty} g[p-2n]d_{j+1}[n] = \check{a}_{j+1} * h[n] + \check{d}_{j+1} * g[n] \quad (4)$$

$$\check{x}[n] = \begin{cases} x[p] & n = 2p \\ 0 & n = 2p + 1 \end{cases}$$

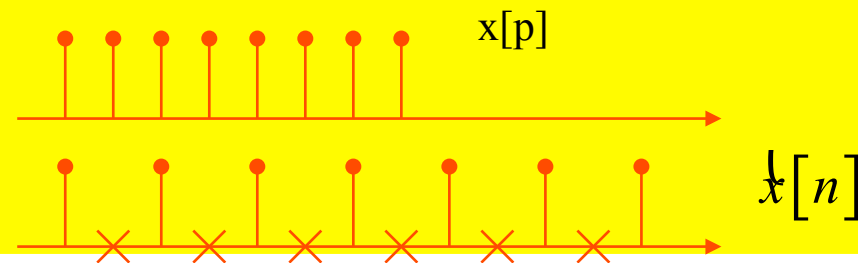

Proof: decomposition (1)

$$\varphi_{j+1}[p] \in V_{j+1} \subset V_j \rightarrow \varphi_{j+1}[p] = \sum_n \langle \varphi_{j+1}[p], \varphi_j[n] \rangle \varphi_j[n] \quad (\text{b})$$

but

$$\langle \varphi_{j+1}[p], \varphi_j[n] \rangle = \int \frac{1}{\sqrt{2^{j+1}}} \varphi\left(\frac{t-2^{j+1}p}{2^{j+1}}\right) \frac{1}{\sqrt{2^j}} \varphi^*\left(\frac{t-2^j n}{2^j}\right) dt \quad (\text{a})$$

let

$$t' = 2^{-j}t - 2p \rightarrow t = 2^j t' + 2^{j+1}p \rightarrow t - 2^{j+1}p = 2^j t' \rightarrow \frac{t-2^{j+1}p}{2^{j+1}} = \frac{t'}{2}$$

then

$$\varphi\left(\frac{t-2^{j+1}p}{2^{j+1}}\right) = \varphi\left(\frac{t'}{2}\right)$$

$$\varphi^*\left(\frac{t-2^j n}{2^j}\right) = \varphi^*(t' + 2p - n)$$

$$\frac{t'}{2} = \frac{t}{2^{j+1}} - p \rightarrow \frac{t}{2^{j+1}} = \frac{t'}{2} + p \rightarrow \frac{t}{2^j} = t' + 2p$$

replacing into (a)

$$(3) \quad \langle \varphi_{j+1}[p], \varphi_j[n] \rangle = \int \frac{1}{\sqrt{2}} \varphi\left(\frac{t'}{2}\right) \varphi^*(t' + 2p - n) dt' = \left\langle \frac{1}{\sqrt{2}} \varphi\left(\frac{t}{2}\right), \varphi(t + 2p - n) \right\rangle = h[n - 2p]$$

thus (b) becomes

$$\boxed{\varphi_{j+1}[p] = \sum_n h[n - 2p] \varphi_j[n]}$$

Proof: decomposition (2)

- Coming back to the projection coefficients

$$\begin{aligned} a_{j+1}[p] &= \langle f, \varphi_{j+1,p} \rangle = \left\langle f, \sum_n h[n-2p] \varphi_{j,n} \right\rangle = \int_{-\infty}^{+\infty} f \sum_n h[n-2p] \varphi_{j,n}^* dt = \\ &= \sum_n h[n-2p] \int_{-\infty}^{+\infty} f(t) \varphi_{j,n}^*(t) dt = \sum_n h[n-2p] \langle f, \varphi_{j,n} \rangle = \sum_n h[n-2p] a_j[n] \rightarrow \\ &\boxed{a_{j+1}[p] = a_j * \bar{h}[2p]} \end{aligned}$$

- Similarly, one can prove the relations for both the details and the reconstruction formula

Proof: decomposition (3)

- Details

$$\psi_{j+1,p} \in W_{j+1} \subset V_j \rightarrow \psi_{j+1,p} = \sum_n \langle \psi_{j+1,n}, \varphi_{j,n} \rangle \varphi_{j,n}$$

$$t' = 2^{-j}t - 2p \rightarrow$$

(3bis) $\langle \psi_{j+1,n}, \varphi_{j,n} \rangle = \left\langle \frac{1}{\sqrt{2}} \psi \left(\frac{t}{2} \right), \varphi(t - n + 2p) \right\rangle = g[n - 2p] \rightarrow$

$$\psi_{j+1,p} = \sum_n g[n - 2p] \varphi_{j,n} \rightarrow$$

$$\langle f, \psi_{j+1,n} \rangle = \sum_n g[n - 2p] \langle f, \varphi_{j,n} \rangle \rightarrow$$

$$d_{j+1}[p] = \sum_n g[n - 2p] a_j[n]$$

Proof: Reconstruction

Since W_{j+1} is the orthonormal complement of V_{j+1} in V_j , the union of the two respective basis is a basis for V_j . Hence

$$V_j = V_{j+1} \oplus W_{j+1} \rightarrow \varphi_{j,p} = \sum_n \langle \varphi_{j,p}, \varphi_{j+1,n} \rangle \varphi_{j+1,n} + \sum_n \langle \varphi_{j,p}, \psi_{j+1,n} \rangle \psi_{j+1,n}$$

but $\langle \varphi_{j,p}, \varphi_{j+1,n} \rangle = h[p - 2n]$ (see (3) and (3bis), the analogous one for g)

$$\langle \varphi_{j,p}, \psi_{j+1,n} \rangle = g[p - 2n]$$

thus

$$\varphi_{j,p} = \sum_n h[p - 2n] \varphi_{j+1,n} + \sum_n g[p - 2n] \psi_{j+1,n}$$

Taking the scalar product with f at both sides:

$$a_j[p] = \sum_{n=-\infty}^{+\infty} h[p - 2n] a_{j+1}[n] + \sum_{n=-\infty}^{+\infty} g[p - 2n] d_{j+1}[n] = \check{a}_{j+1} * h[n] + \check{d}_{j+1} * g[n]$$

CVD

$$\check{x}[n] = \begin{cases} x[p] & n = 2p \\ 0 & n = 2p + 1 \end{cases}$$

Summary

- The coefficients a_{j+1} and d_{j+1} are computed by taking every other sample of the convolution of a_j with \bar{h} and \bar{g} respectively.
- The filter \bar{h} *removes* the higher frequencies of the inner product sequence a_j , whereas \bar{g} is a high-pass filter that *collects* the remaining highest frequencies.
- The reconstruction is an interpolation that inserts zeroes to expand a_{j+1} and d_{j+1} and filters these signals, as shown in Figure.

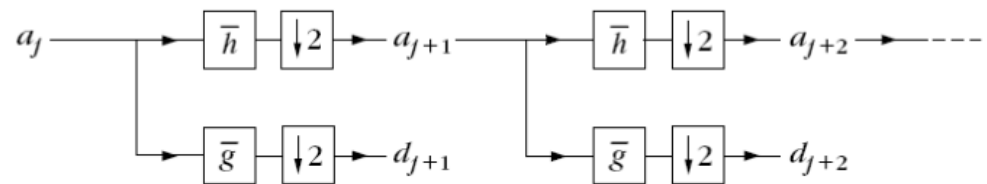

(a)

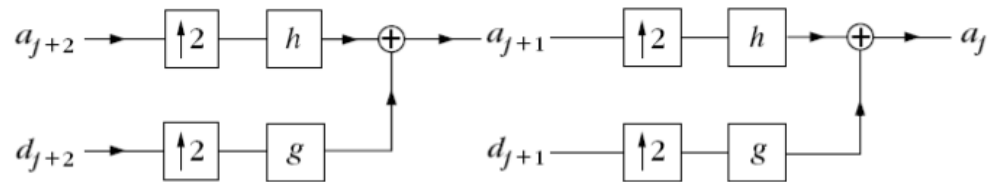

(b)

Filterbank implementation

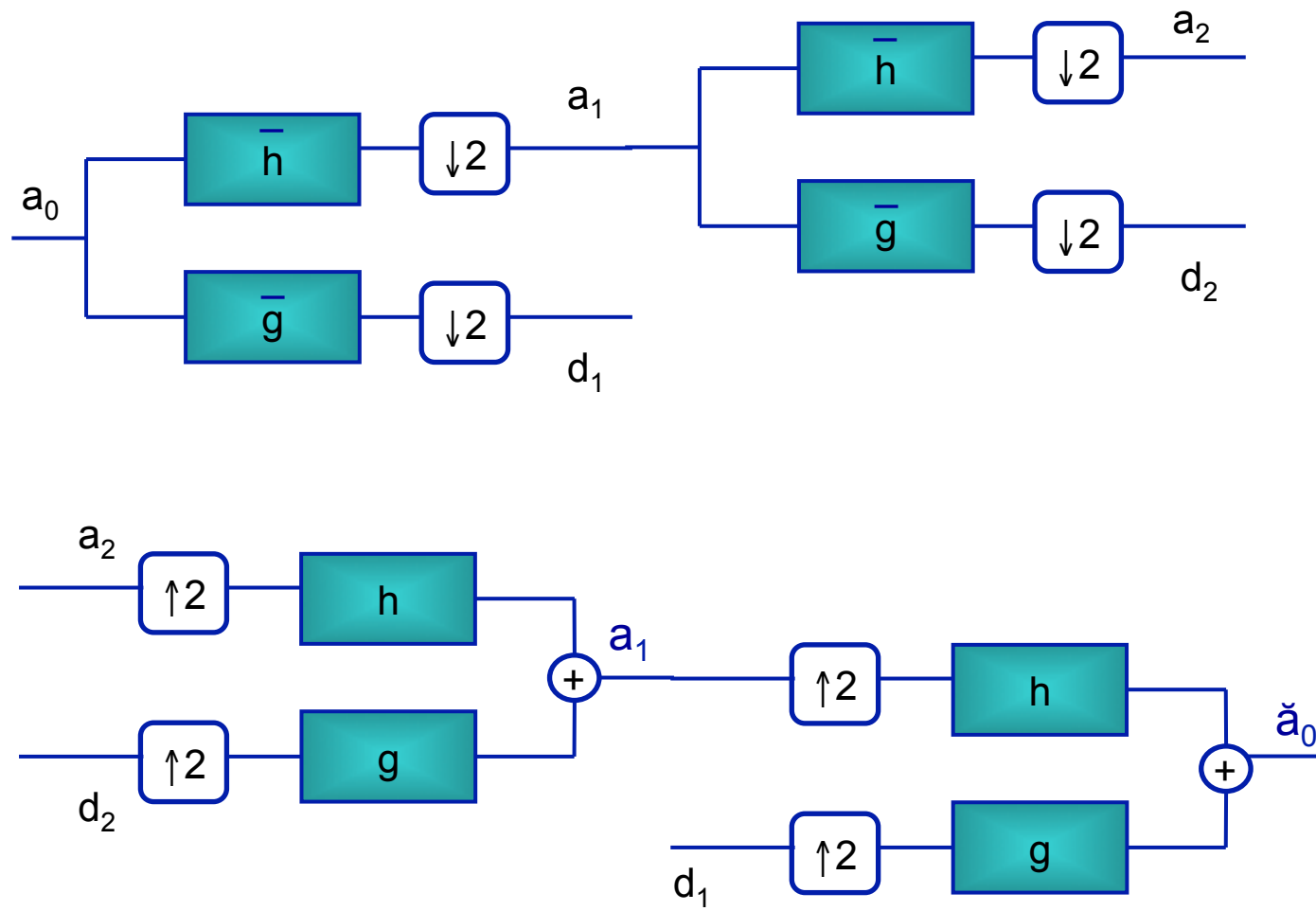

Fast DWT

- Theorem 7.10 proves that a_{j+1} and d_{j+1} are computed by taking every other sample of the convolution on a_j with \bar{h} and \bar{g} respectively
- The filter h removes the higher frequencies of the inner product and the filter g is a band-pass filter that collects such residual frequencies
- An orthonormal **wavelet representation** is composed of wavelet coefficients at scales

$$1 \leq 2^j \leq 2^J$$

plus the remaining approximation at scale 2^J

$$\left[\left\{ d_j \right\}_{1 \leq j \leq J}, a_J \right]$$

Summary

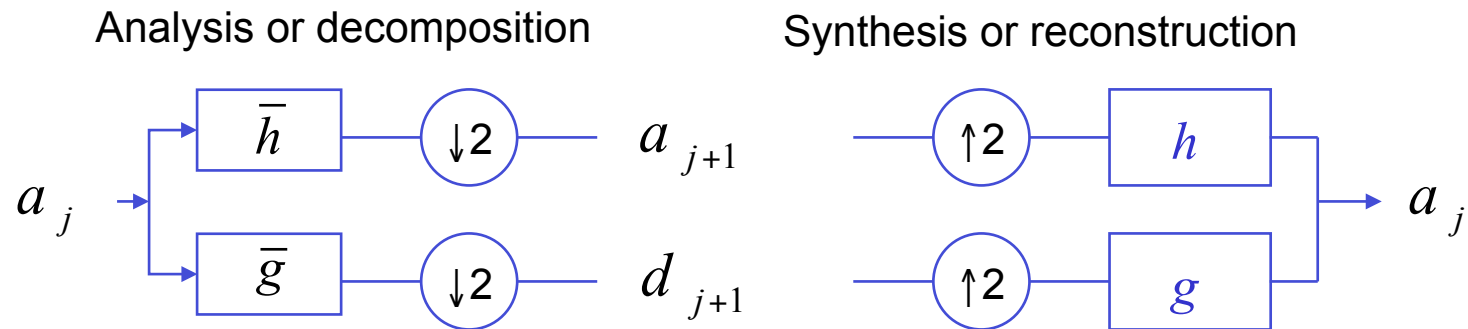

Theorem 7.2 (Mallat&Meyer) and **Theorem 7.3** [Mallat&Meyer] 

$$\forall \omega \in \mathbb{R}, \quad |\hat{h}(\omega)|^2 + |\hat{h}(\omega + \pi)|^2 = 2$$

and

$$\hat{h}(0) = \sqrt{2}$$

$$\hat{g}(\omega) = e^{-j\omega} \hat{h}^*(\omega + \pi) \Leftrightarrow g[n] = (-1)^{1-n} h[1-n]$$

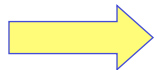

The fast orthogonal WT is implemented by a filterbank that is completely specified by the filter h , which is a CMF
The filters are the same for every j

Filter bank perspective

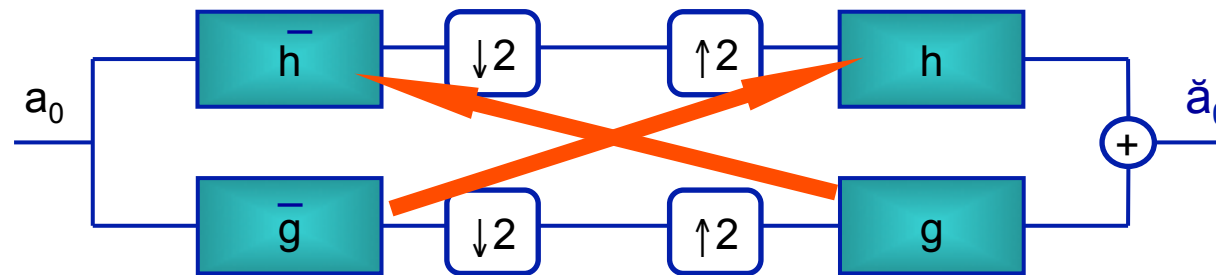

Taking $h[n]$ as reference (which amounts to choosing **the synthesis low-pass filter**) the following relations hold for an orthogonal filter bank:

$$\bar{h}[n] = h[-n]$$

$$g[n] = (-1)^{1-n} h[1-n] = (-1)^{1-n} \bar{h}[n-1]$$

$$\bar{g}[n] = g[-n] = (-1)^{-(1-n)} h[-(1-n)]$$

neglecting the unitary shift, as usually done in applications

$$g[n] = (-1)^{-n} h[-n] = (-1)^{-n} \bar{h}[n]$$

$$\bar{g}[n] = g[-n] = (-1)^n h[n]$$

Finite signals

- Issue: signal extension at borders
- Possible solutions:
 - Periodic extension
 - Works with any kind of wavelet
 - Generates large coefficients at the borders
 - Symmetry/antisymmetric extension, depending on the wavelet symmetry
 - More difficult implementation
 - Haar filter is the only symmetric filter with compact support
 - Use different wavelets at boundary (boundary wavelets)
 - Implementation by *lifting steps*

Wavelet graphs

The graphs of ϕ and ψ are computed numerically with the inverse wavelet transform. If $f = \phi$, then $a_0[n] = \delta[n]$ and $d_j[n] = 0$ for all $L < j \leq 0$. The inverse wavelet transform computes a_L and (7.111) shows that

$$N^{1/2} a_L[n] \approx \phi(N^{-1}n).$$

If ϕ is regular and N is large enough, we recover a precise approximation of the graph of ϕ from a_L .

Similarly, if $f = \psi$, then $a_0[n] = 0$, $d_0[n] = \delta[n]$, and $d_j[n] = 0$ for $L < j < 0$. Then $a_L[n]$ is calculated with the inverse wavelet transform and $N^{1/2} a_L[n] \approx \psi(N^{-1}n)$. The Daubechies wavelets and scaling functions in Figure 7.10 are calculated with this procedure.

Orthogonal wavelet representation

- An *orthogonal wavelet representation* of $a_L = \langle f, \varphi_{L,n} \rangle$ is composed of wavelet coefficients of f at scales $2^L < 2^j \leq 2^J$, plus the remaining approximation at the largest scale 2^J :

$$[\{d_j\}_{L < j \leq J}, a_J].$$

- **Initialization**

- Let $b[n]$ be the discrete time input signal and let N^{-1} be the sampling period, such that the corresponding scale is $2^L = N^{-1}$
- Then:

$$f(t) = \sum_{n=-\infty}^{+\infty} b[n] \phi\left(\frac{t - 2^L n}{2^L}\right) \in \mathbf{V}_L.$$

N^{-1} : discrete sample distance
 $2^L = N^{-1}$ scale

original continuous time signal discrete time signal interpolation function

Initialization

following the definition:

N^{-1} : discrete sample distance

$2^L = N^{-1}$ scale

$$\varphi_{L,n} = \frac{1}{\sqrt{2^L}} \varphi\left(\frac{t - 2^L n}{2^L}\right)$$

$$2^L = \frac{1}{N} \rightarrow \frac{1}{\sqrt{2^L}} = N^{1/2} = \sqrt{N} \rightarrow \varphi_{L,n} = \sqrt{N} \varphi\left(\frac{t - N^{-1}n}{N^{-1}}\right) \rightarrow \varphi\left(\frac{t - N^{-1}n}{N^{-1}}\right) = \frac{1}{\sqrt{N}} \varphi_{L,n}$$

but

$$f(t) = \sum_{n=-\infty}^{+\infty} b[n] \varphi\left(\frac{t - N^{-1}n}{N^{-1}}\right) = \frac{1}{\sqrt{N}} \sum_{n=-\infty}^{+\infty} b[n] \varphi_{L,n}(t)$$

$$b[n] = \left\langle f, \varphi\left(\frac{t - N^{-1}n}{N^{-1}}\right) \right\rangle = \left\langle f, \frac{1}{\sqrt{N}} \varphi_{L,n} \right\rangle = \frac{1}{\sqrt{N}} a_L[n] \quad a_L[n] = \langle f, \varphi_{L,n} \rangle$$

since

$$a_L[n] = \int_{-\infty}^{+\infty} f(t) \sqrt{N} \varphi\left(\frac{t - N^{-1}n}{N^{-1}}\right) dt \quad \text{by definition, then}$$

$$a_L[n] \approx \sqrt{N} f(N^{-1}n) \quad \text{if } f \text{ is regular, the sampled values can be considered as a local average in the neighborhood of } f(N^{-1}n)$$

The filter bank perspective

Perfect reconstruction FB

- **Dual perspective:** given a filterbank consisting of 4 filters, we derive the *perfect reconstruction conditions*

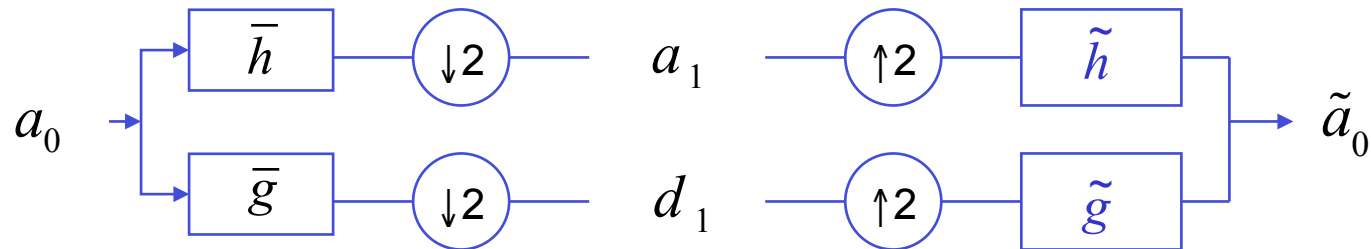

- Goal: determine the conditions on the filters ensuring that

$$\tilde{a}_0 \equiv a_0$$

PR Filter banks

- The decomposition of a discrete signal in a multirate filter bank is interpreted as an expansion in $l^2(\mathbb{Z})$

since

$$a_1[l] = a_0 * \bar{h}[2l] = \sum_n a_0[n] \bar{h}[2l - n] = \sum_n a_0[n] h[n - 2l]$$

then

$$a_1[l] = \sum_{n=-\infty}^{+\infty} a_0[n] h[n - 2l] = \langle a_0[n], h[n - 2l] \rangle,$$

$$d_1[l] = \sum_{n=-\infty}^{+\infty} a_0[n] g[n - 2l] = \langle a_0[n], g[n - 2l] \rangle.$$

and the signal is recovered by the reconstruction filter

$$a_0[n] = \sum_{l=-\infty}^{+\infty} a_1[l] \tilde{h}[n - 2l] + \sum_{l=-\infty}^{+\infty} d_1[l] \tilde{g}[n - 2l].$$

thus

$$a_0[n] = \sum_{l=-\infty}^{+\infty} \langle f[k], h[k - 2l] \rangle \tilde{h}[n - 2l] + \sum_{l=-\infty}^{+\infty} \langle f[k], g[k - 2l] \rangle \tilde{g}[n - 2l].$$

dual family of vectors



points to
biorthogonal
wavelets

The two families are biorthogonal

Theorem 7.13. If h , g , \tilde{h} , and \tilde{g} are perfect reconstruction filters, and their Fourier transforms are bounded, then $\{\tilde{h}[n - 2l], \tilde{g}[n - 2l]\}_{l \in \mathbb{Z}}$ and $\{h[n - 2l], g[n - 2l]\}_{l \in \mathbb{Z}}$ are biorthogonal Riesz bases of $\ell^2(\mathbb{Z})$.

Thus, a PR FB projects a discrete time signals over a biorthogonal basis of $\ell^2(\mathbb{Z})$.
If the dual basis is the same as the original basis than the projection is orthonormal.

Discrete Wavelet basis

- Question: why bother with the construction of wavelet basis if a PR FB can do the same easily?
- Answer: because conjugate mirror filters are most often used in filter banks that cascade several levels of filterings and subsamplings. Thus, it is necessary to understand the behavior of such a cascade

N^{-1} : discrete sample distance

$2^L = N^{-1}$ scale

$$a_L[n] = \langle f, \varphi_{L,n} \rangle \quad \text{discrete signal at scale } 2^L$$

$$\varphi\left(\frac{t - N^{-1}n}{N^{-1}}\right) = \frac{1}{\sqrt{N}} \varphi_{L,n}$$

for depth $j-L > 0$

$$a_j[l] = a_L \star \bar{\phi}_j[2^{j-L}l] = \langle a_L[n], \phi_j[n - 2^{j-L}l] \rangle$$

$$d_j[l] = a_L \star \bar{\psi}_j[2^{j-L}l] = \langle a_L[n], \psi_j[n - 2^{j-L}l] \rangle.$$

$$\hat{\phi}_j(\omega) = \prod_{p=0}^{j-L-1} \hat{h}(2^p \omega)$$

$$\hat{\psi}_j(\omega) = \hat{g}(2^{j-L-1} \omega) \prod_{p=0}^{j-L-2} \hat{h}(2^p \omega).$$

Discrete wavelet basis

For conjugate mirror filters, one can verify that this family is an orthonormal basis of $\ell^2(\mathbb{Z})$. These discrete vectors are close to a uniform sampling of the continuous time-scaling functions $\phi_j(t) = 2^{-j/2}\phi(2^{-j}t)$ and wavelets $\psi_j(t) = 2^{-j/2}\psi(2^{-j}t)$. When the number $L - j$ of successive convolutions increases, one can verify that $\phi_j[n]$ and $\psi_j[n]$ converge, respectively, to $N^{-1/2}\phi_j(N^{-1}n)$ and $N^{-1/2}\psi_j(N^{-1}n)$.

The factor $N^{-1/2}$ normalizes the $\ell^2(\mathbb{Z})$ norm of these sampled functions. If $L - j = 4$, then $\phi_j[n]$ and $\psi_j[n]$ are already very close to these limit values. Thus, the impulse responses $\phi_j[n]$ and $\psi_j[n]$ of the filter bank are much closer to continuous time-scaling functions and wavelets than they are to the original conjugate mirror filters h and g . This explains why wavelets provide appropriate models for understanding the applications of these filter banks. Chapter 8 relates more general filter banks to wavelet packet bases.

Perfect reconstruction FB

- **Theorem 7.7 (Vetterli)** The FB performs an exact reconstruction for any input signal iif

$$\begin{aligned}\hat{h}^*(\omega)\hat{\tilde{h}}(\omega) + \hat{g}^*(\omega)\hat{\tilde{g}}(\omega) &= 2 \\ \hat{h}^*(\omega + \pi)\hat{\tilde{h}}(\omega) + \hat{g}^*(\omega + \pi)\hat{\tilde{g}}(\omega) &= 0\end{aligned}\quad (\textit{alias free})$$

Matrix notations

$$\begin{pmatrix} \hat{h}^*(\omega) \\ \hat{g}^*(\omega) \end{pmatrix} = \frac{2}{\Delta(\omega)} \begin{pmatrix} \hat{g}(\omega + \pi) \\ -\hat{h}(\omega + \pi) \end{pmatrix}$$
$$\Delta(\omega) = \hat{h}(\omega)\hat{g}(\omega + \pi) - \hat{h}(\omega + \pi)\hat{g}(\omega)$$

When all the filters are FIR, the determinant can be evaluated, which yields simpler relations between the decomposition and the reconstruction filters.

Changing the sampling rate

- Downsampling

$$\hat{y}(2\omega) = \frac{1}{2}(\hat{x}(\omega) + \hat{x}(\omega + \pi)) = \sum_{n=-\infty}^{+\infty} x[2n]e^{-jn\omega}$$

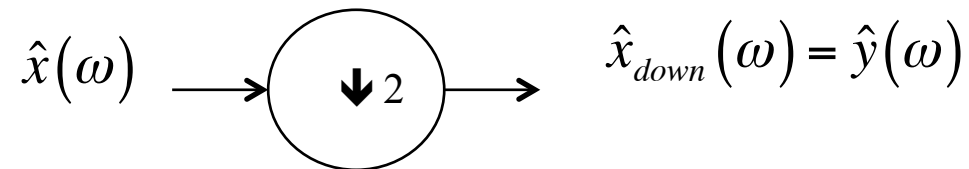

$$\hat{y}(\omega) = \frac{1}{2} \left(\hat{x}\left(\frac{\omega}{2}\right) + \hat{x}\left(\frac{\omega}{2} + \pi\right) \right)$$

- Upsampling

$$\hat{y}(\omega) = \hat{x}(2\omega) = \sum_{n=-\infty}^{+\infty} x[n]e^{-j2n\omega}$$

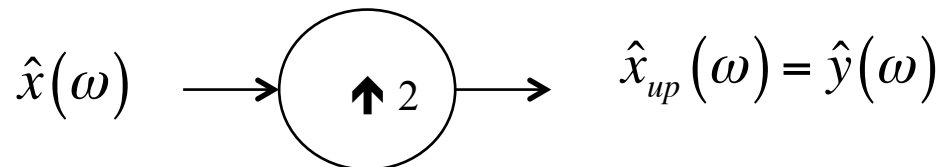

Subsampling: proof

$$\begin{aligned}\hat{y}(\omega) &= \dots y[0] + y[1]e^{-j\omega} + y[2]e^{-j2\omega} + \dots = \\ &= \dots x[0] + x[2]e^{-j\omega} + x[4]e^{-j2\omega} + \dots \rightarrow\end{aligned}$$

thus

$$\hat{y}(2\omega) = \dots x[0] + x[2]e^{-j2\omega} + x[4]e^{-j4\omega} + \dots$$

but

$$x[1]e^{-j\omega} + x[1]e^{-j(\omega+\pi)} = 0 \rightarrow \frac{1}{2}(x[1]e^{-j\omega} + x[1]e^{-j(\omega+\pi)}) = 0$$

$$x[2]e^{-j2\omega} = \frac{1}{2}(x[2]e^{-j2\omega} + x[2]e^{-j2(\omega+\pi)})$$

thus

$$\hat{y}(2\omega) = \dots x[0] + \frac{1}{2}(x[1]e^{-j\omega} + x[1]e^{-j(\omega+\pi)}) + \frac{1}{2}(x[2]e^{-j2\omega} + x[2]e^{-j2(\omega+\pi)}) + \dots =$$

$$\hat{y}(2\omega) = \frac{1}{2}(\hat{x}(\omega) + \hat{x}(\omega + \pi))$$

Perfect Reconstruction conditions

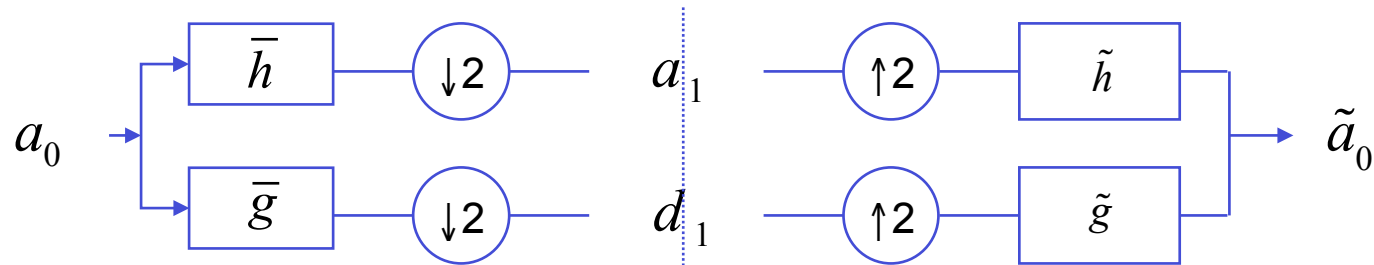

$$a_1(2\omega) = \frac{1}{2} \left(a_0(\omega) \hat{h}(\omega) + a_0(\omega + \pi) \hat{h}(\omega + \pi) \right)$$

since h and g are real

$$h[n] \rightarrow h(\omega)$$

$$h[-n] = \bar{h}[n] \rightarrow \hat{h}(\omega) = \hat{h}(-\omega) = h^*(\omega)$$

thus, replacing in the first equation

$$a_1(2\omega) = \frac{1}{2} \left(a_0(\omega) \hat{h}^*(\omega) + a_0(\omega + \pi) \hat{h}^*(\omega + \pi) \right)$$

Similarly, for the high-pass branch

$$d_1(2\omega) = \frac{1}{2} \left(a_0(\omega) \hat{g}^*(\omega) + a_0(\omega + \pi) \hat{g}^*(\omega + \pi) \right)$$

$$\hat{a}_0(\omega) = \hat{a}_1(2\omega) \hat{h}(\omega) + \hat{d}_1(2\omega) \hat{g}(\omega)$$

Perfect Reconstruction conditions

- Putting all together

$$\begin{aligned}
 \hat{\tilde{a}}_0(\omega) &= \hat{a}_1(2\omega)\hat{\tilde{h}}(\omega) + \hat{d}_1(2\omega)\hat{\tilde{g}}(\omega) = \\
 &= \frac{1}{2} \left(a_0(\omega)\hat{h}^*(\omega) + a_0(\omega+\pi)\hat{h}^*(\omega+\pi) \right) \hat{\tilde{h}}(\omega) \\
 &\quad + \frac{1}{2} \left(a_0(\omega)\hat{g}^*(\omega) + a_0(\omega+\pi)\hat{g}^*(\omega+\pi) \right) \hat{\tilde{g}}(\omega) \\
 \hat{\tilde{a}}_0(\omega) &= \frac{1}{2} \left(\hat{h}^*(\omega)\hat{\tilde{h}}(\omega) + \hat{g}^*(\omega)\hat{\tilde{g}}(\omega) \right) a_0(\omega) + \frac{1}{2} \left(\hat{h}^*(\omega+\pi)\hat{\tilde{h}}(\omega) + \hat{g}^*(\omega+\pi)\hat{\tilde{g}}(\omega) \right) a_0(\omega+\pi) \\
 &\qquad\qquad\qquad = 1 \qquad\qquad\qquad\qquad\qquad\qquad\qquad\qquad\qquad\qquad\qquad\qquad\qquad = 0 \quad (\text{alias-free})
 \end{aligned}$$

$$\begin{aligned}
 \hat{h}^*(\omega)\hat{\tilde{h}}(\omega) + \hat{g}^*(\omega)\hat{\tilde{g}}(\omega) &= 2 \\
 \hat{h}^*(\omega+\pi)\hat{\tilde{h}}(\omega) + \hat{g}^*(\omega+\pi)\hat{\tilde{g}}(\omega) &= 0
 \end{aligned}$$

(alias free)

Matrix notations

$$\begin{pmatrix} \hat{\tilde{h}}^*(\omega) \\ \hat{\tilde{g}}^*(\omega) \end{pmatrix} = \frac{2}{\Delta(\omega)} \begin{pmatrix} \hat{g}(\omega+\pi) \\ -\hat{h}(\omega+\pi) \end{pmatrix}$$

$$\Delta(\omega) = \hat{h}(\omega)\hat{g}(\omega+\pi) - \hat{h}(\omega+\pi)\hat{g}(\omega)$$

PR filters

- Theorem 7.8. Perfect reconstruction filters also satisfy

$$\hat{h}^*(\omega)\tilde{h}(\omega) + \hat{h}^*(\omega + \pi)\tilde{h}(\omega + \pi) = 2$$

Furthermore, if the filters have a finite impulse response there exists a in R and l in Z such that

$$\begin{aligned} \hat{g}(\omega) &= ae^{-i(2l+1)\omega}\tilde{h}^*(\omega + \pi) \\ \tilde{\hat{g}}(\omega) &= \frac{1}{a}e^{-i(2l+1)\omega}\hat{h}^*(\omega + \pi) \end{aligned} \quad \Rightarrow \quad a=1, l=0 \quad \Rightarrow$$

$$\begin{aligned} \hat{g}(\omega) &= e^{-j\omega}\tilde{h}^*(\omega + \pi) \\ \tilde{\hat{g}}(\omega) &= e^{-j\omega}\hat{h}^*(\omega + \pi) \end{aligned}$$

Correspondingly

$$\begin{aligned} g[n] &= (-1)^{1-n}\tilde{h}[1-n] \\ \tilde{g}[n] &= (-1)^{1-n}h[1-n] \end{aligned}$$

- Conjugate Mirror Filters:

$$\tilde{h} = h \rightarrow \left| \hat{h}(\omega) \right|^2 + \left| \hat{h}(\omega + \pi) \right|^2 = 2$$

Proof

Given h and \tilde{h} and setting $a=1$ and $l=0$ in (2) the remaining filters are given by the following relations

$$(3) \quad \begin{aligned} \hat{g}(\omega) &= e^{-i\omega} \hat{h}^*(\omega + \pi) \\ \tilde{g}(\omega) &= e^{-i\omega} \tilde{h}^*(\omega + \pi) \end{aligned}$$

- The filters h and \tilde{h} are related to the scaling functions φ and $\tilde{\varphi}$ via the corresponding two-scale relations, as was the case for the orthogonal filters (see eq. 1).

Switching to the z -domain

$$\begin{aligned} g(z) &= z^{-1} \tilde{h}(-z^{-1}) \\ \tilde{g}(z) &= z^{-1} h(-z^{-1}) \end{aligned}$$

Signal domain

$$\begin{aligned} g[n] &= (-1)^{1-n} \tilde{h}[1-n] \\ \tilde{g}[n] &= (-1)^{1-n} h[1-n] \end{aligned}$$

Biorthogonal filter banks

- A 2-channel multirate filter bank convolves a signal a_0 with

a low pass filter

$$\bar{h}[n] = h[-n]$$

and a high pass filter

$$\bar{g}[n] = g[-n]$$

and sub-samples the output by 2

$$a_1[n] = a_0 * \bar{h}[2n]$$

$$d_1[n] = a_0 * \bar{g}[2n]$$

A reconstructed signal \tilde{a}_0 is obtained by filtering the zero-expanded signals with a *dual low-pass* $\tilde{h}[n]$ and *high pass filter* $\tilde{g}[n]$

$$\tilde{a}_0[n] = \tilde{a}_1 * \tilde{h}[n] + \tilde{d}_1 * \tilde{g}[n]$$
$$y[n] = \tilde{x}[n] = \begin{cases} x[p] & n = 2p \\ 0 & n = 2p + 1 \end{cases}$$

Imposing the PR condition (output signal=input signal) one gets the relations that the different filters must satisfy (Theorem 7.7)

Revisiting the orthogonal case (CMF)

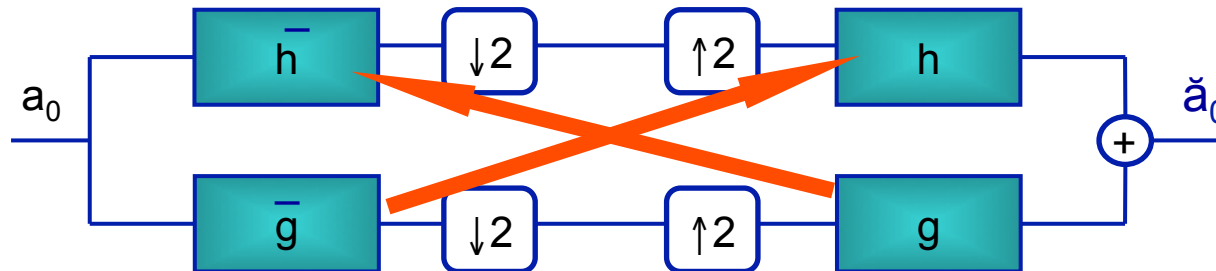

Taking $\bar{h}[n] = h[-n]$ as reference (which amounts to choosing the analysis low-pass filter) the following relations hold for an orthogonal filter bank:

$\bar{h}[n] = h[-n] \leftrightarrow h[n] = \bar{h}[-n]$ synthesis low-pass (interpolation) filter:
reverse the order of the coefficients

$g[n] = (-1)^{1-n} h[1-n]$ negate every other sample

Orthogonal vs biorthogonal PRFB

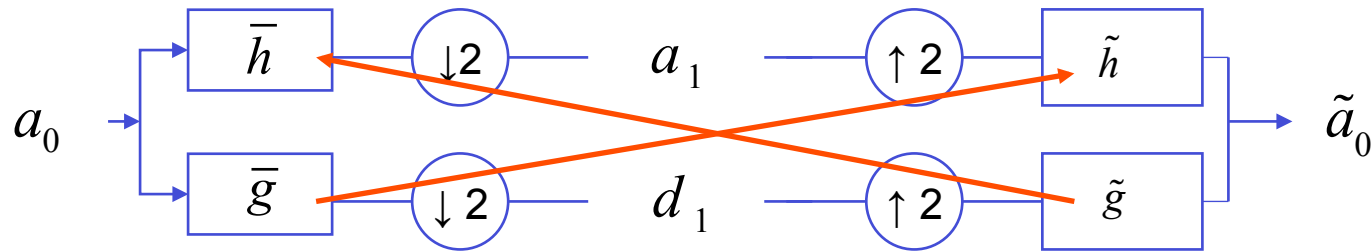

$\tilde{h} \neq h$ Biorthogonal PRFB

$$\hat{h}^*(\omega)\hat{\tilde{h}}(\omega) + \hat{h}^*(\omega + \pi)\hat{\tilde{h}}(\omega + \pi) = 2$$

$$\hat{g}(\omega) = e^{-j\omega}\hat{\tilde{h}}^*(\omega + \pi)$$

$$\hat{\tilde{g}}(\omega) = e^{-j\omega}\hat{h}^*(\omega + \pi)$$

In the signal domain

$$g[n] = (-1)^{1-n}\tilde{h}[1-n]$$

$$\tilde{g}[n] = (-1)^{1-n}h[1-n]$$

$\tilde{h} = h$ Orthogonal PRFB

$$|\hat{h}(\omega)|^2 + |\hat{h}(\omega + \pi)|^2 = 2$$

$$\tilde{g} = g$$

Fast BWT

- Two different sets of basis functions are used for analysis and synthesis

$$a_{j+1}[n] = a_j * \bar{h}[2n]$$

$$d_{j+1}[n] = a_j * \bar{g}[2n]$$

$$a_j[n] = \tilde{a}_{j+1} * \tilde{h}[n] + \tilde{d}_{j+1} * \tilde{g}[n]$$

- PR filterbank

$$g[n] = (-1)^{1-n} \tilde{h}[1-n]$$

$$\tilde{g}[n] = (-1)^{1-n} h[1-n]$$

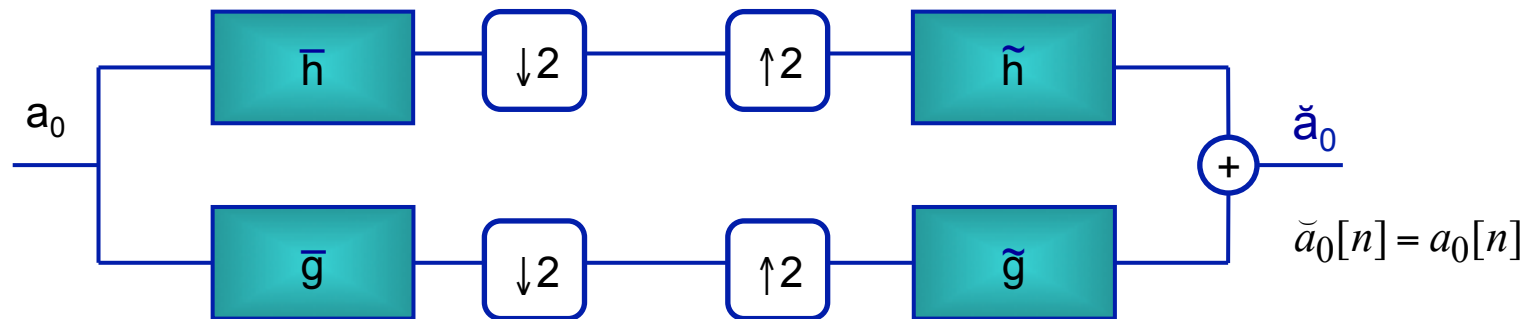

Be careful with notations!

- In the simplified notation where
 - $h[n]$ is the analysis low pass filter and $g[n]$ is the analysis high pass filter, as it is the case in most of the literature;
 - the delay factor is not made explicit;
- The relations among the filters modify as follows

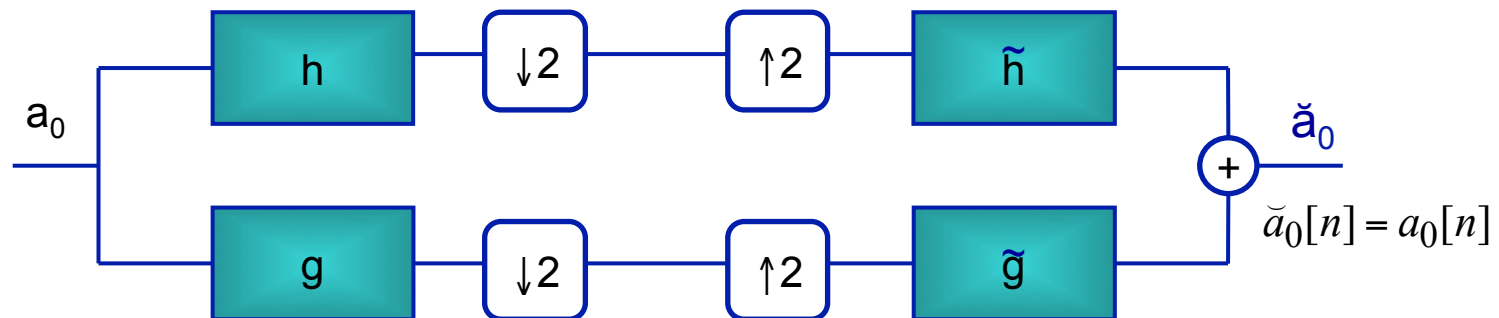

$$g[n] = (-1)^{-n} \tilde{h}[n]$$

$$\tilde{g}[n] = (-1)^{-n} h[n]$$

The high pass filters are obtained by the low pass filters by negating the odd terms

Biorthogonal bases

Orthonormal basis

$\{e_n\}_{n \in \mathbb{N}}$: basis of Hilbert space

Orthogonality condition $\langle e_n, e_p \rangle = 0 \quad \forall n \neq p$

$\forall y \in H,$

There exists a sequence

$$\lambda[n] = \langle y, e_n \rangle:$$

$$y = \sum_n \lambda[n] e_n$$

$|e_n|^2 = 1$ ortho-normal basis

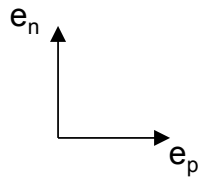

Bi-orthogonal basis

$\{e_n\}_{n \in \mathbb{N}}$: linearly independent

$\forall y \in H, \quad \exists A > 0$ and $B > 0$:

$$\lambda[n] = \langle y, e_n \rangle:$$

$$y = \sum_n \lambda[n] \tilde{e}_n$$

$$\frac{|y|^2}{B} \leq \sum_n |\lambda[n]|^2 \leq \frac{|y|^2}{A}$$

Biorthogonality condition:

$$\langle e_n, \tilde{e}_p \rangle = \delta[n - p]$$

$$y = \sum_n \langle f, \tilde{e}_n \rangle e_n = \sum_n \langle f, e_n \rangle \tilde{e}_n$$

$A=B=1 \Rightarrow$ orthogonal basis

Biorthogonal bases

If h and \tilde{h} are FIR

$$\hat{\Phi}(\omega) = \prod_{p=1}^{+\infty} \frac{\hat{h}(2^{-p}\omega)}{\sqrt{2}} \hat{\Phi}(0), \quad \hat{\tilde{\Phi}}(\omega) = \prod_{p=1}^{+\infty} \frac{\hat{h}(2^{-p}\omega)}{\sqrt{2}} \hat{\tilde{\Phi}}(0)$$

Though, some other conditions must be imposed to guarantee that φ^\wedge and $\varphi^\wedge\tilde{}$ are FT of finite energy functions. The theorem from Cohen, Daubechies and Feaveau provides *sufficient* conditions (Theorem 7.10)

The functions $\hat{\phi}$ and $\hat{\tilde{\phi}}$ satisfy the biorthogonality relation

$$\langle \varphi(t), \tilde{\varphi}(t-n) \rangle = \delta[n]$$

The two wavelet families $\left\{ \psi_{j,n} \right\}_{(j,n) \in \mathbb{Z}^2}$ and $\left\{ \tilde{\psi}_{j,n} \right\}_{(j,n) \in \mathbb{Z}^2}$ are Riesz bases of $L^2(\mathbb{R})$

$$\langle \psi_{j,n}, \tilde{\psi}_{j',n'} \rangle = \delta[n-n'] \delta[j-j']$$

Any $f \in L^2(\mathbb{R})$ has two possible decompositions in these bases

$$f = \sum_{n,j} \langle f, \psi_{j,n} \rangle \tilde{\psi}_{j,n} = \sum_{n,j} \langle f, \tilde{\psi}_{j,n} \rangle \psi_{j,n}$$

Summary of Biorthogonality relations

- An infinite cascade of PR filter banks $(h, g), (\tilde{h}, \tilde{g})$ yields two scaling functions and two wavelets whose Fourier transform satisfy

$$\hat{\Phi}(2\omega) = \frac{1}{\sqrt{2}} \hat{h}(\omega) \hat{\Phi}(\omega) \quad \Leftrightarrow \quad \varphi\left(\frac{t}{2}\right) = \sum_{n=-\infty}^{+\infty} h[n] \varphi(t-n) \quad (i)$$

$$\hat{\tilde{\Phi}}(2\omega) = \frac{1}{\sqrt{2}} \hat{\tilde{h}}(\omega) \hat{\tilde{\Phi}}(\omega) \quad \Leftrightarrow \quad \tilde{\varphi}\left(\frac{t}{2}\right) = \sum_{n=-\infty}^{+\infty} \tilde{h}[n] \tilde{\varphi}(t-n) \quad (ii)$$

$$\hat{\Psi}(2\omega) = \frac{1}{\sqrt{2}} \hat{g}(\omega) \hat{\Phi}(\omega) \quad \Leftrightarrow \quad \psi\left(\frac{t}{2}\right) = \sum_{n=-\infty}^{+\infty} g[n] \varphi(t-n) \quad (iii)$$

$$\hat{\tilde{\Psi}}(2\omega) = \frac{1}{\sqrt{2}} \hat{\tilde{g}}(\omega) \hat{\tilde{\Phi}}(\omega) \quad \Leftrightarrow \quad \tilde{\psi}\left(\frac{t}{2}\right) = \sum_{n=-\infty}^{+\infty} \tilde{g}[n] \tilde{\varphi}(t-n) \quad (iv)$$

Properties of biorthogonal filters

Imposing the zero average condition to ψ in equations (iii) and (iv)

$$\hat{\Psi}(0) = \hat{\tilde{\Psi}}(0) = 0 \rightarrow \hat{g}(0) = \hat{\tilde{g}}(0) = 0$$

replacing into the relations (3) (also shown below)

$$\hat{g}(\omega) = e^{-i\omega} \hat{h}^*(\omega + \pi) \quad \hat{\tilde{g}}(\omega) = e^{-i\omega} \hat{\tilde{h}}^*(\omega + \pi) \rightarrow \hat{h}^*(\pi) = \hat{\tilde{h}}(\pi) = 0$$

Furthermore, replacing such values in the PR condition (1)

$$\hat{h}^*(\omega) \hat{h}(\omega) + \hat{g}^*(\omega) \hat{\tilde{g}}(\omega) = 2 \rightarrow \hat{h}^*(0) \hat{h}(0) = 2$$

It is common choice to set

$$\hat{h}^*(0) = \hat{h}(0) = \sqrt{2}$$

Biorthogonal bases

- If the decomposition and reconstruction filters are different, the resulting bases is non-orthogonal
- The cascade of J levels is equivalent to a signal decomposition over a non-orthogonal bases

$$\left[\left\{ \varphi_J [k - 2^J n] \right\}_{n \in \mathbb{Z}}, \left\{ \psi_j [k - 2^j n] \right\}_{1 \leq j \leq J, n \in \mathbb{Z}} \right]$$

- The dual bases is needed for reconstruction

Example: bior3.5

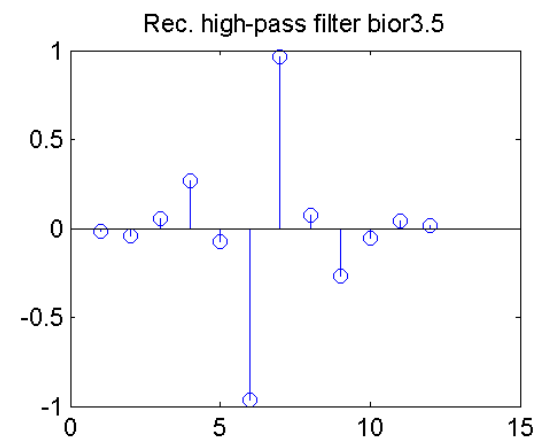
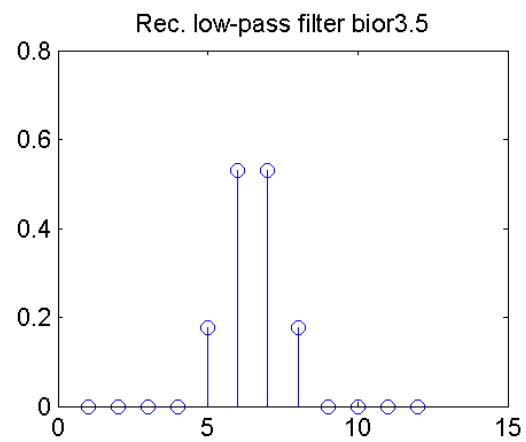
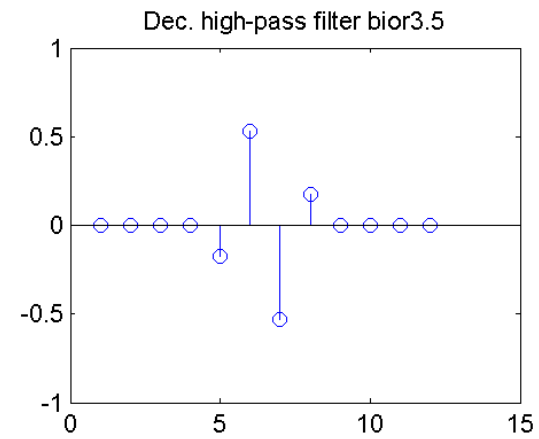
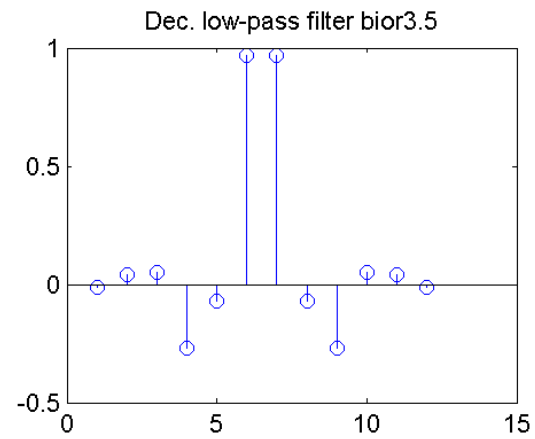

Example: bior3.5

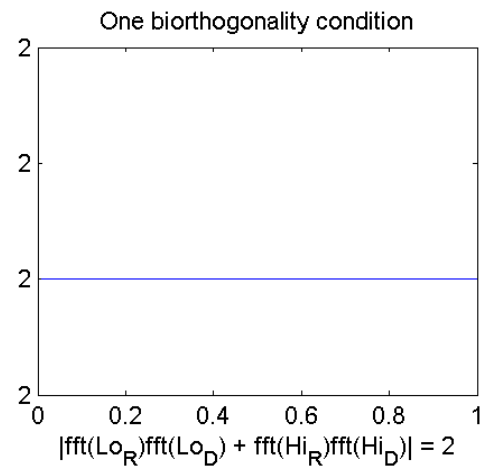
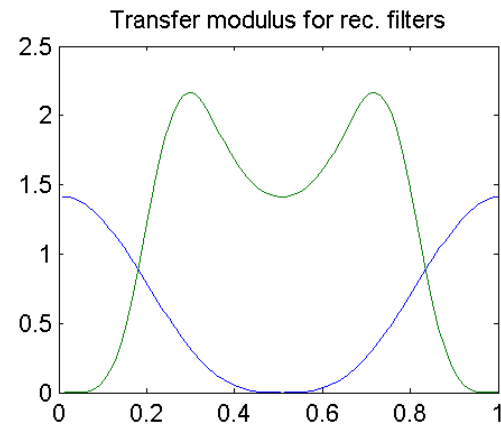
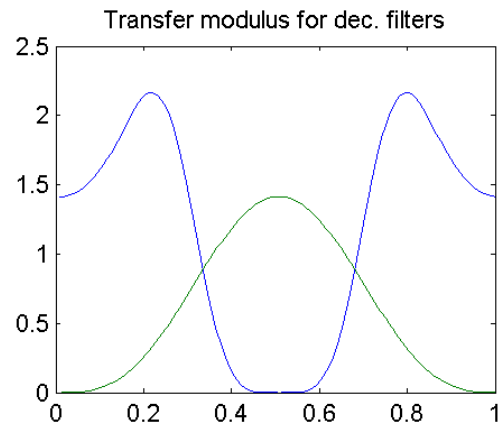

Biorthogonal bases

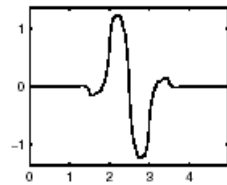

bior1.3

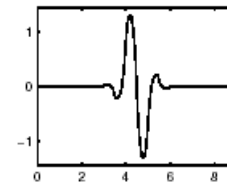
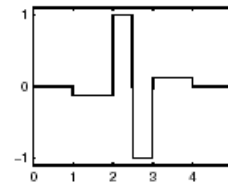

bior1.5

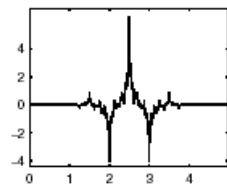
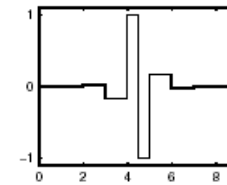

bior2.2

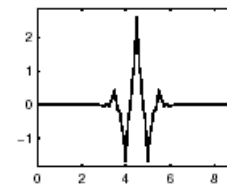
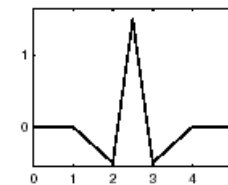

bior2.4

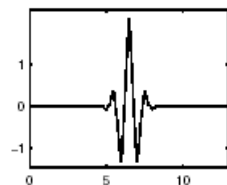
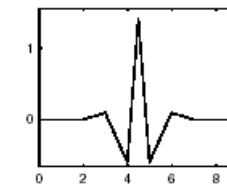

bior2.6

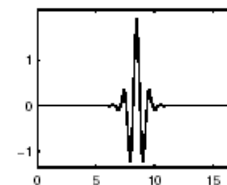
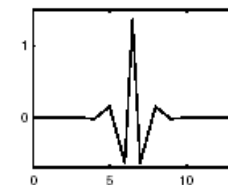

bior2.8

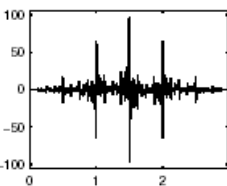
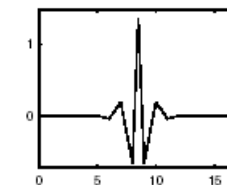

bior3.1

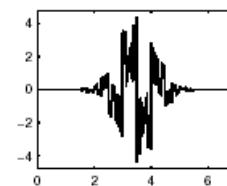
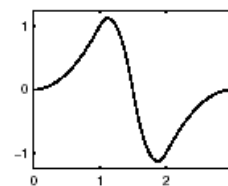

bior3.3

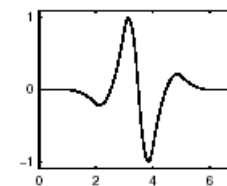

Biorthogonal bases

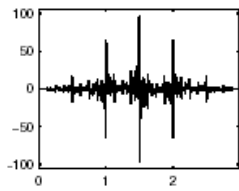

bior3.1

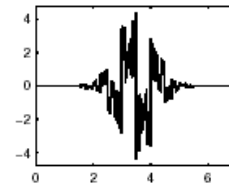
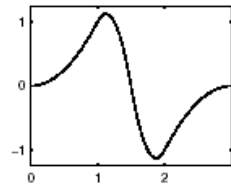

bior3.3

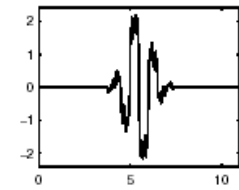
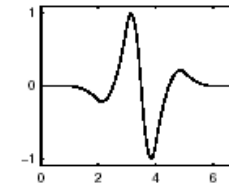

bior3.5

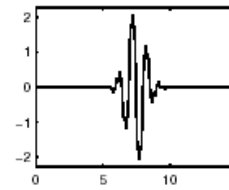
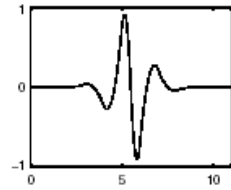

bior3.7

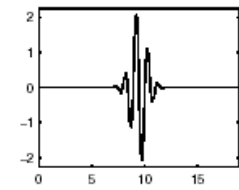
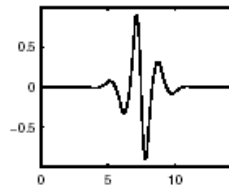

bior3.9

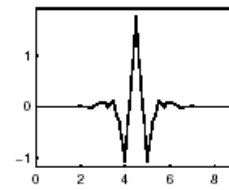
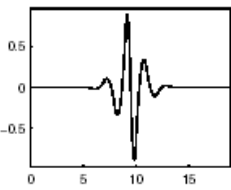

bior4.4

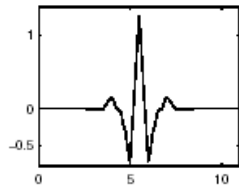
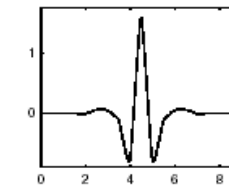

bior5.5

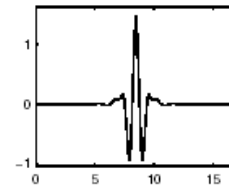
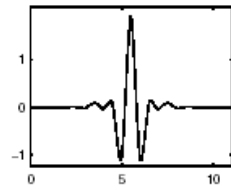

bior6.8

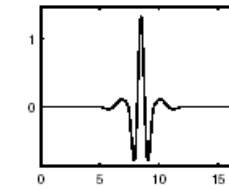

CMF : orthogonal filters

- PR filter banks decompose the signals in a basis of $l^2(\mathbb{Z})$. This basis is *orthogonal* for *Conjugate Mirror Filters* (CMF).
- [Smith&Barnwell,1984]: Necessary and sufficient condition for PR *orthogonal FIR* filter banks, called CMFs
 - Imposing that *the decomposition filter h is equal to the reconstruction filter h^{\sim}* , eq. (1) becomes

$$\hat{h}^*(\omega)\hat{\tilde{h}}(\omega) + \hat{h}^*(\omega + \pi)\hat{\tilde{h}}(\omega + \pi) = 2 \quad (1) \rightarrow$$

$$\hat{h}^*(\omega)\hat{h}(\omega) + \hat{h}^*(\omega + \pi)\hat{h}(\omega + \pi) = 2 \rightarrow$$

$$|\hat{h}(\omega)|^2 + |\hat{h}(\omega + \pi)|^2 = 2$$

- Correspondingly

$$\tilde{h}[n] = h[n]$$

$$\tilde{g}[n] = g[n] = (-1)^{1-n} h[1-n]$$

Summary

- PR filter banks decompose the signals in a basis of $l^2(Z)$. This basis is *orthogonal* for *Conjugate Mirror Filters* (CMF).
- [Smith&Barnwell,1984]: Necessary and sufficient condition for PR **orthogonal FIR** filter banks, called **CMFs**
 - Imposing that the decomposition filter h is equal to the reconstruction filter \tilde{h} , eq. (1) becomes

$$\hat{h}^*(\omega)\hat{\tilde{h}}(\omega) + \hat{h}^*(\omega + \pi)\hat{\tilde{h}}(\omega + \pi) = 2 \rightarrow$$

$$\hat{h}^*(\omega)\hat{h}(\omega) + \hat{h}^*(\omega + \pi)\hat{h}(\omega + \pi) = 2 \rightarrow$$

- Correspondingly $|\hat{h}(\omega)|^2 + |\hat{h}(\omega + \pi)|^2 = 2$

$$\tilde{h}[n] = h[n]$$

$$\tilde{g}[n] = g[n] = (-1)^{1-n} h[1-n]$$

Properties

- **Support**
 - h, \tilde{h} are FIR \rightarrow scaling functions and wavelets have compact support
- **Vanishing moments**
 - The number of vanishing moments of Ψ is equal to the order \tilde{p} of zeros of \tilde{h} in π . Similarly, the number of vanishing moments of $\tilde{\psi}$ is equal to the order p of zeros of h in π .
- **Regularity**
 - One can show that the regularity of Ψ and ϕ increases with the number of vanishing moments of $\tilde{\psi}$, thus with the order p of zeros of h in π . Viceversa, the regularity of $\tilde{\psi}$ and $\tilde{\phi}$ increases with the number of vanishing moments of Ψ , thus with the order \tilde{p} of zeros of \tilde{h} in π .
- **Symmetry**
 - It is possible to construct both symmetric and anti-symmetric bases using linear phase filters
 - In the orthogonal case only the Haar filter is possible as FIR solution.