

Wavelets bases in higher dimensions

Topics

Basic issues

- Separable spaces and bases
- Separable wavelet bases (2D DWT)
- Fast 2D DWT
- *Lifting steps* scheme
- JPEG2000

Wavelets in vision

- Human Visual System

Advanced concepts

- Overcomplete bases
 - Discrete wavelet frames (DWF)
 - Algorithme à trous
 - Discrete dyadic wavelet frames (DDWF)
- Overview on edge sensitive wavelets
 - Contourlets

Separable Wavelet bases

- In general, to any wavelet orthonormal basis $\{\psi_{j,n}\}_{(j,n) \in \mathbb{Z}^2}$ of $\mathbf{L}^2(\mathbb{R})$, one can associate a separable wavelet orthonormal basis of $\mathbf{L}^2(\mathbb{R}^2)$:

$$\left\{ \psi_{j_1, n_1}(x_1) \psi_{j_2, n_2}(x_2) \right\}_{(j_1, j_2, n_1, n_2) \in \mathbb{Z}^4}$$

- The functions $\psi_{j_1, n_1}(x_1)$ and $\psi_{j_2, n_2}(x_2)$ mix information at two different scales along x_1 and x_2 , which is something that we could want to avoid
- *Separable multiresolutions* lead to another construction of separable wavelet bases with wavelets that are products of functions dilated at the same scale.

Separable multiresolutions

- The notion of resolution is formalized with orthogonal projections in spaces of various sizes.
- The approximation of an image $f(x_1, x_2)$ at the resolution 2^{-j} is defined as the orthogonal projection of f on a space \mathbf{V}_j^2 that is included in $\mathbf{L}^2(\mathbf{R}^2)$
- The space \mathbf{V}_j^2 is the set of all approximations at the resolution 2^{-j} .
 - When the resolution decreases, the size of \mathbf{V}_j^2 decreases as well.
- The formal definition of a multiresolution approximation $\{\mathbf{V}_j^2\}_{j \in \mathbf{Z}}$ of $\mathbf{L}^2(\mathbf{R}^2)$ is a straightforward extension of Definition 7.1 that specifies multiresolutions of $\mathbf{L}^2(\mathbf{R})$.
 - The same causality, completeness, and scaling properties must be satisfied.

Separable spaces and bases

- Tensor product
 - Used to extend spaces of 1D signals to spaces of multi-dimensional signals
 - A tensor product $x_1 \otimes x_2$ between vectors of two Hilbert spaces H_1 and H_2 satisfies the following properties

Linearity

$$\forall \lambda \in \mathbb{C}, \lambda(x_1 \otimes x_2) = (\lambda x_1) \otimes x_2 = x_1 \otimes (\lambda x_2)$$

Distributivity

$$(x_1 + y_1) \otimes (x_2 + y_2) = (x_1 \otimes x_2) + (x_1 \otimes y_2) + (y_1 \otimes x_2) + (y_1 \otimes y_2) +$$

- This tensor product yields a new Hilbert space $H = H_1 \otimes H_2$ including all the vectors of the form $x_1 \otimes x_2$ where $x_1 \in H_1$ and $x_2 \in H_2$ as well as a linear combination of such vectors
- An inner product for H is derived as $\langle x_1 \otimes x_2, y_1 \otimes y_2 \rangle = \langle x_1, y_1 \rangle_{H_1} \langle x_2, y_2 \rangle_{H_2}$

Separable bases

- **Theorem A.3** Let $H = H_1 \otimes H_2$. If $\{e_n^1\}_{n \in \mathbb{N}}$ and $\{e_n^2\}_{n \in \mathbb{N}}$ are Riesz bases of H_1 and H_2 , respectively, then $\{e_n^1 \otimes e_m^2\}_{n,m \in \mathbb{N}^2}$ is a Riesz basis for H . If the two bases are orthonormal then the tensor product basis is also orthonormal.

→ To any wavelet orthonormal basis one can associate a separable wavelet orthonormal basis of $L^2(\mathbb{R}^2)$

$$\{\psi_{j,n}(x), \psi_{l,m}(y)\}_{(j,n,l,m) \in \mathbb{Z}^4}$$

However, wavelets $\psi_{j,n}(x)$ and $\psi_{l,m}(y)$ mix the information at *two different scales* along x and y , which often we want to avoid.

Separable Wavelet bases

- Separable multiresolutions lead to another construction of separable wavelet bases whose elements are products of functions *dilated at the same scale*.
- We consider the particular case of separable multiresolutions
- A **separable 2D multiresolution** is composed of the tensor product spaces

$$V_j^2 = V_j \otimes V_j$$

- V_j^2 is the space of finite energy functions $f(x,y)$ that are linear expansions of separable functions

$$f(x,y) = \sum_n a[n] f_n(x) g_n(y) \quad f_n \in V_j \quad g_n \in V_j$$

- If $\{V_j\}_{j \in \mathbb{Z}}$ is a multiresolution approximation of $L^2(\mathbb{R})$, then $\{V_j^2\}_{j \in \mathbb{Z}}$ is a multiresolution approximation of $L^2(\mathbb{R}^2)$.

Separable bases

It is possible to prove (Theorem A.3) that

$$\left\{ \varphi_{j,n,m}(x,y) = \varphi_{j,n}(x)\varphi_{j,m}(y) = \frac{1}{2^j} \varphi\left(\frac{x-2^j n}{2^j}\right) \varphi\left(\frac{y-2^j m}{2^j}\right) \right\}_{(n,m) \in \mathbb{Z}^2}$$

is an orthonormal basis of V_j^2 .

A 2D wavelet basis is constructed with separable products of a scaling function and a wavelet

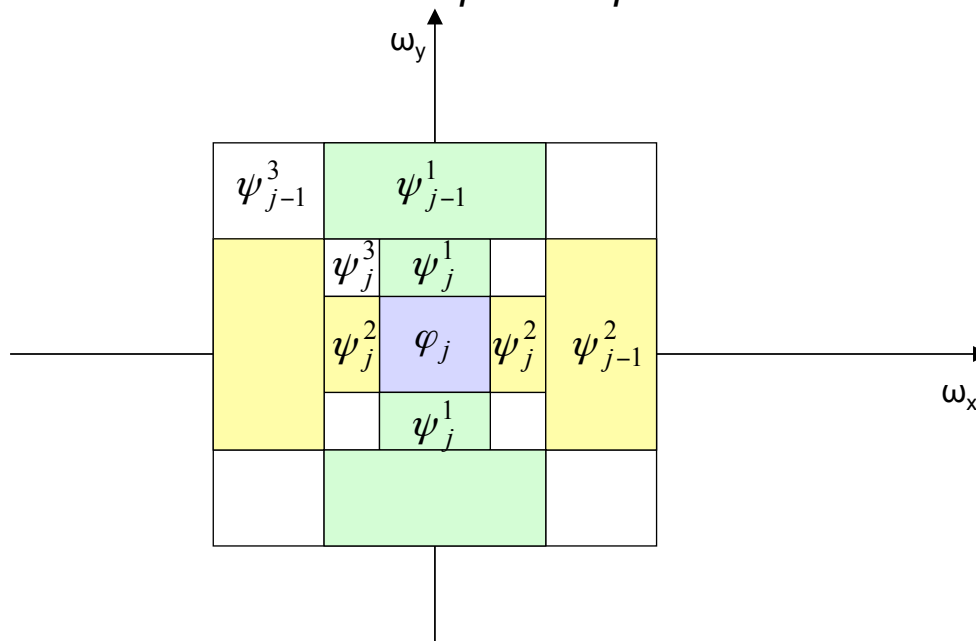

Examples

EXAMPLE 7.13: Piecewise Constant Approximation

Let \mathbf{V}_j be the approximation space of functions that are constant on $[2^j m, 2^j(m+1)]$ for any $m \in \mathbb{Z}$. The tensor product defines a two-dimensional piecewise constant approximation. The space \mathbf{V}_j^2 is the set of functions that are constant on any square $[2^j n_1, 2^j(n_1+1)] \times [2^j n_2, 2^j(n_2+1)]$, for $(n_1, n_2) \in \mathbb{Z}^2$. The two-dimensional scaling function is

$$\phi^2(x) = \phi(x_1) \phi(x_2) = \begin{cases} 1 & \text{if } 0 \leq x_1 \leq 1 \text{ and } 0 \leq x_2 \leq 1 \\ 0 & \text{otherwise.} \end{cases}$$

EXAMPLE 7.14: Shannon Approximation

Let \mathbf{V}_j be the space of functions with Fourier transforms that have a support included in $[-2^{-j}\pi, 2^{-j}\pi]$. Space \mathbf{V}_j^2 is the set of functions the two-dimensional Fourier transforms of which have a support included in the low-frequency square $[-2^{-j}\pi, 2^{-j}\pi] \times [-2^{-j}\pi, 2^{-j}\pi]$. The two-dimensional scaling function is a perfect two-dimensional low-pass filter the Fourier transform of which is

$$\hat{\phi}(\omega_1) \hat{\phi}(\omega_2) = \begin{cases} 1 & \text{if } |\omega_1| \leq 2^{-j}\pi \text{ and } |\omega_2| \leq 2^{-j}\pi \\ 0 & \text{otherwise.} \end{cases}$$

Separable wavelet bases

- A separable wavelet orthonormal basis of $\mathbf{L}^2(\mathbb{R}^2)$ is constructed with separable products of a scaling function and a wavelet .
- The scaling function is associated to a one-dimensional multiresolution approximation $\{\mathbf{V}_j\}_{j \in \mathbb{Z}}$.
- Let $\{\mathbf{V}_j^2\}_{j \in \mathbb{Z}}$ be the separable two-dimensional multiresolution defined by

$$V_j^2 = V_j \otimes V_j$$

- Let \mathbf{W}_j^2 be the detail space equal to the orthogonal complement of the lower-resolution approximation space \mathbf{V}_j^2 in \mathbf{V}_{j-1}^2 :

$$V_{j-1}^2 = V_j^2 \oplus W_j^2$$

- To construct a wavelet orthonormal basis of $\mathbf{L}^2(\mathbb{R}^2)$, Theorem 7.25 builds a wavelet basis of each detail space \mathbf{W}_j^2 .

Separable wavelet bases

Theorem 7.25

Let φ be a scaling function and ψ be the corresponding wavelet generating an orthonormal basis of $L^2(\mathbb{R})$. We define three wavelets

$$\psi^1(x, y) = \varphi(x)\psi(y)$$

$$\psi^2(x, y) = \psi(x)\varphi(y)$$

and denote for $1 \leq k \leq 3$

$$\psi^3(x, y) = \psi(x)\psi(y)$$

$$\psi_{j,n,m}^k(x, y) = \frac{1}{2^j} \psi^k\left(\frac{x - 2^j n}{2^j}, \frac{y - 2^j m}{2^j}\right)$$

The wavelet family

$$\left\{ \psi_{j,n,m}^1(x, y), \psi_{j,n,m}^2(x, y), \psi_{j,n,m}^3(x, y) \right\}_{(n,m) \in \mathbb{Z}^2}$$

is an orthonormal basis of W_j^2 and

$$\left\{ \psi_{j,n,m}^1(x, y), \psi_{j,n,m}^2(x, y), \psi_{j,n,m}^3(x, y) \right\}_{(j,n,m) \in \mathbb{Z}^3}$$

is an orthonormal basis of $L^2(\mathbb{R}^2)$

On the same line, one can define **biorthogonal** 2D bases.

Separable wavelet bases

- The three wavelets extract image *details* at different scales and in *different directions*.
- Over positive frequencies, $\hat{\varphi}(\omega)$ and $\hat{\psi}(\omega)$ have an energy mainly concentrated, respectively, in $[0, \pi]$ and $[\pi, 2\pi]$.
- The separable wavelet expressions imply that

$$\hat{\psi}^1(\omega_x, \omega_y) = \hat{\varphi}(\omega_x) \hat{\psi}(\omega_y)$$

$$\hat{\psi}^2(\omega_x, \omega_y) = \hat{\psi}(\omega_x) \hat{\varphi}(\omega_y)$$

$$\hat{\psi}^3(\omega_x, \omega_y) = \hat{\psi}(\omega_x) \hat{\psi}(\omega_y)$$

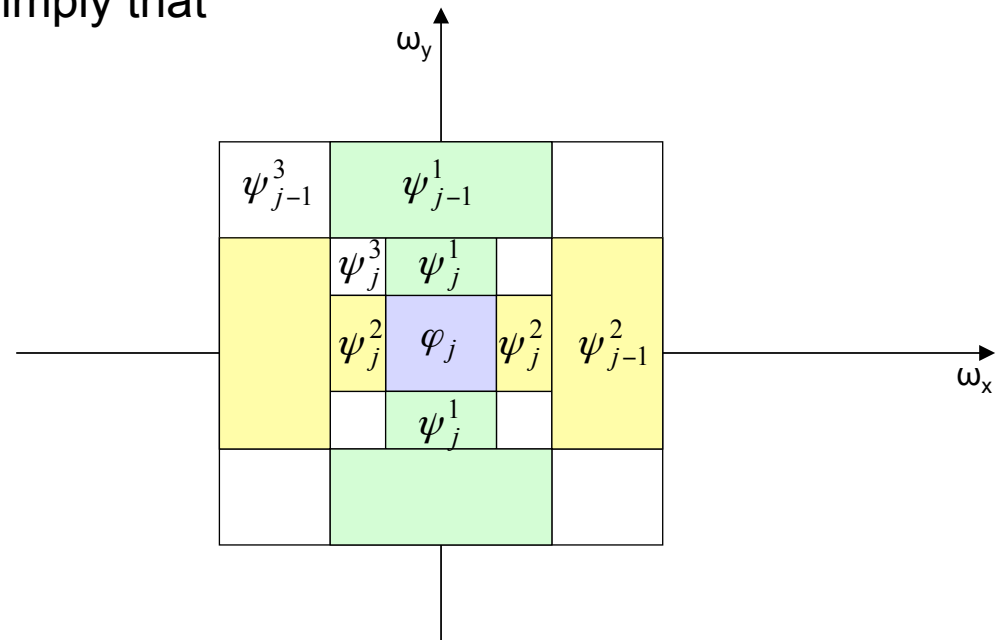

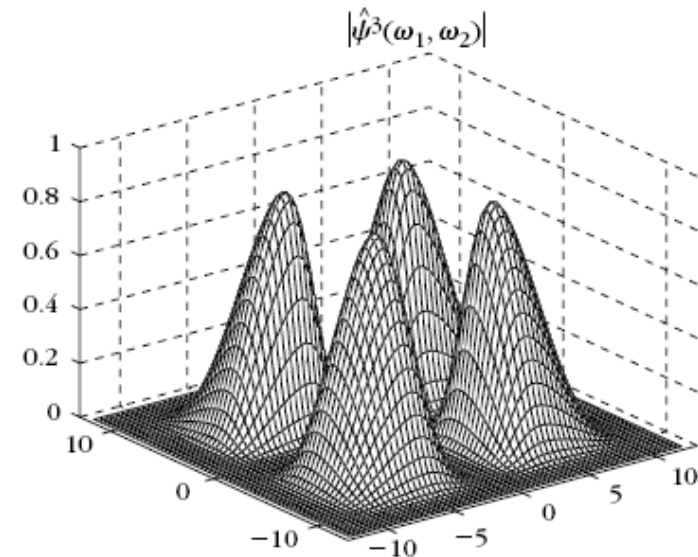
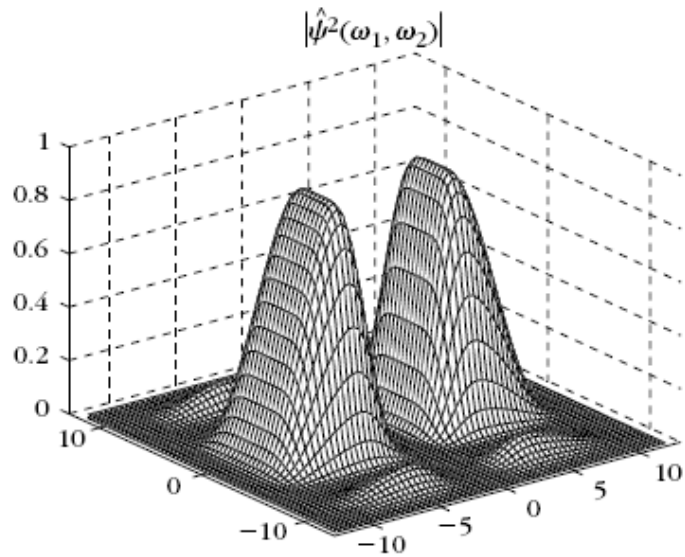
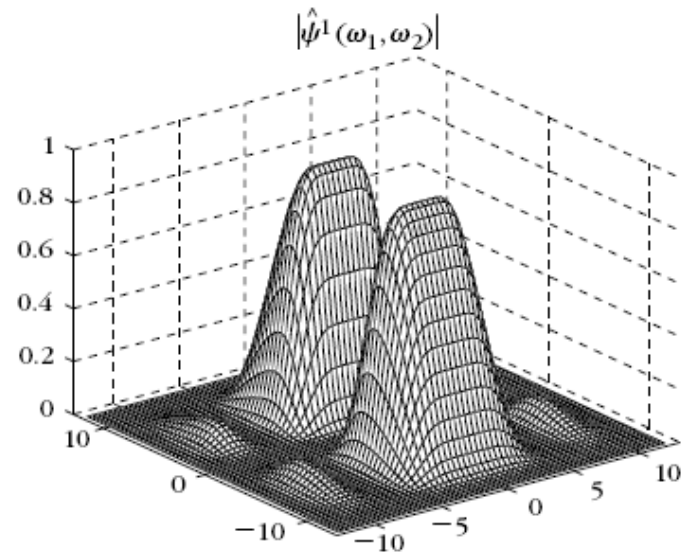
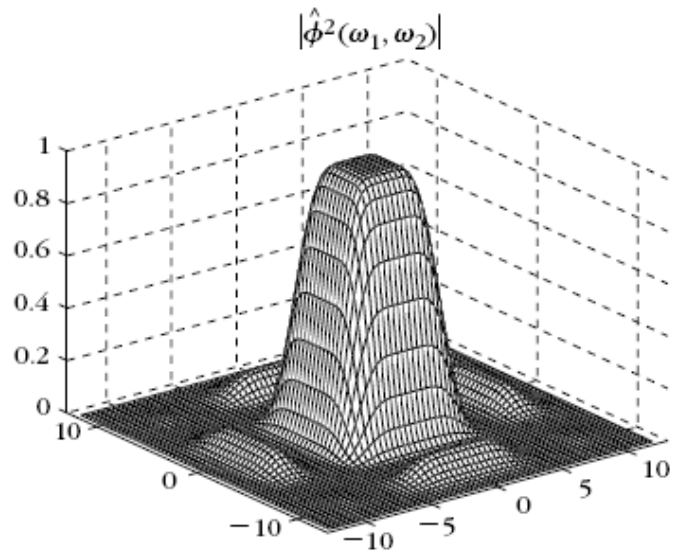

Bi-dimensional wavelets

$$\varphi(x, y) = \varphi(x)\varphi(y)$$

$$\psi^1(x, y) = \varphi(x)\psi(y)$$

$$\psi^2(x, y) = \psi(x)\varphi(y)$$

$$\psi^3(x, y) = \psi(x)\psi(y)$$

coif2: phi(x)*phi(y).

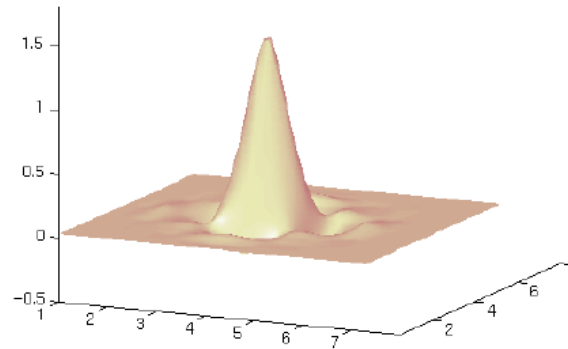

coif2: phi(x)*psi(y).

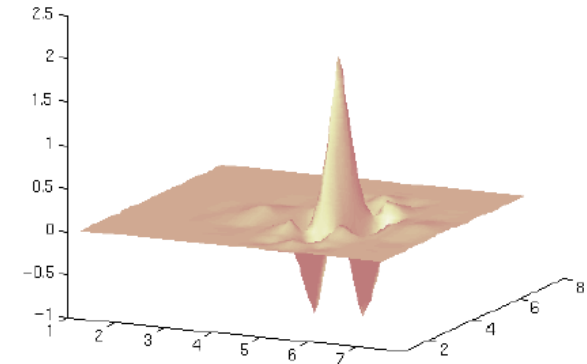

coif2: psi(x)*phi(y).

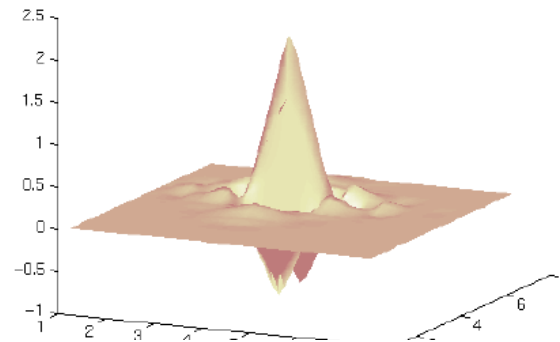

coif2: psi(x)*psi(y).

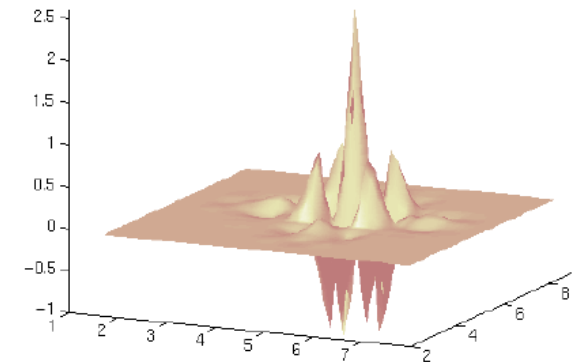

$$\frac{1}{\sqrt{a_1 a_2}} \psi\left(\frac{x_1 - b_1}{a_1}, \frac{x_2 - b_2}{a_2}\right) \text{ where } (x = (x_1, x_2) \in \mathbb{R}^2)$$

Example: Shannon wavelets

EXAMPLE 7.16

For a Shannon multiresolution approximation, the resulting two-dimensional wavelet basis paves the two-dimensional Fourier plane (ω_1, ω_2) with dilated rectangles. The Fourier transforms $\hat{\phi}$ and $\hat{\psi}$ are the indicator functions of $[-\pi, \pi]$ and $[-2\pi, -\pi] \cup [\pi, 2\pi]$, respectively. The separable space \mathbf{V}_j^2 contains functions with a two-dimensional Fourier transform support included in the low-frequency square $[-2^{-j}\pi, 2^{-j}\pi] \times [-2^{-j}\pi, 2^{-j}\pi]$. This corresponds to the support of $\hat{\phi}_{j,n}^2$ indicated in Figure 7.23.

The detail space \mathbf{W}_j^2 is the orthogonal complement of \mathbf{V}_j^2 in \mathbf{V}_{j-1}^2 and thus includes functions with Fourier transforms supported in the frequency annulus between the two squares $[-2^{-j}\pi, 2^{-j}\pi] \times [-2^{-j}\pi, 2^{-j}\pi]$ and $[-2^{-j+1}\pi, 2^{-j+1}\pi] \times [-2^{-j+1}\pi, 2^{-j+1}\pi]$.

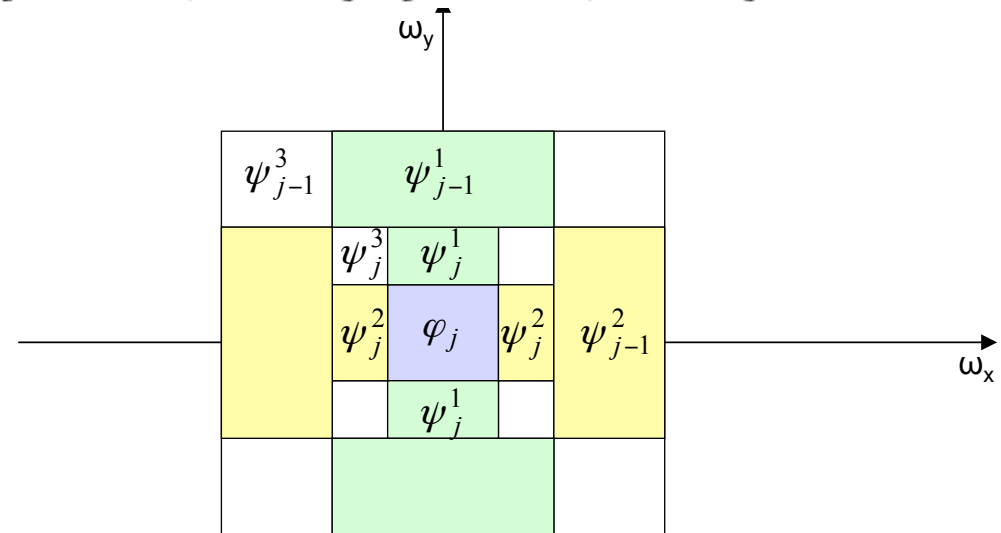

a_{L+3}	d_{L+3}^2	d_{L+2}^2	
d_{L+3}^1	d_{L+3}^3		
d_{L+2}^1	d_{L+2}^3	d_{L+1}^2	
d_{L+1}^1		d_{L+1}^3	

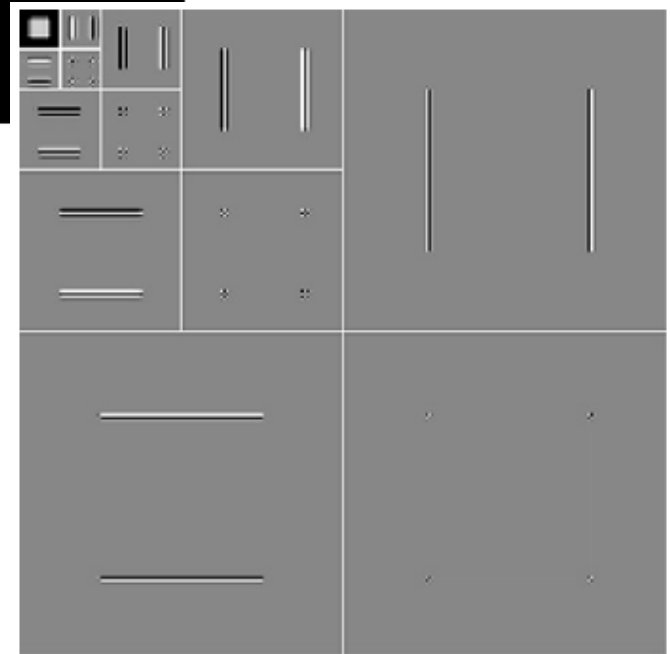
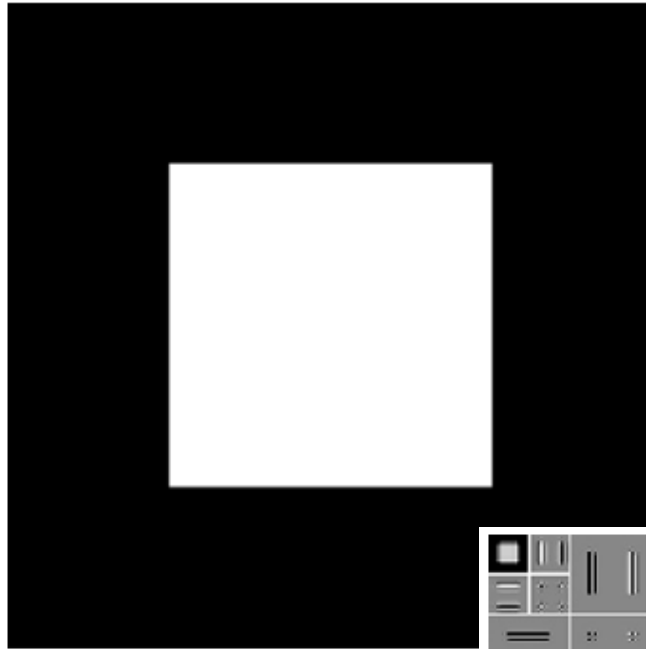

Multiresolution vision

- The visual acuity is greatest at the center of the retina where the density of receptors is maximum. When moving apart from the center, the resolution decreases proportionally to the distance from the retina center
- A retina with a uniform resolution equal to the highest fovea resolution would require about 10,000 times more photoreceptors. Such a uniform resolution retina would increase considerably the size of the optic nerve that transmits the retina information to the visual cortex and the size of the visual cortex that processes this data.
- *Active vision* strategies compensate the non-uniformity of visual resolution with eye saccades, which move successively the fovea over regions of a scene with a high information content. These saccades are partly guided by the lower resolution information gathered at the periphery of the retina. This multiresolution sensor has the advantage of providing high resolution information at *selected locations*, and a large field of view, with relatively little data.

Multiresolution *computer vision*

- Multiresolution algorithms implement in software the search for important high resolution data. A uniform high resolution image is measured by camera but only a small part of this information is processed
- Coarse to fine algorithms analyze first the lower resolution image and selectively increase the resolution in regions where more details are needed.
- Applications: object recognition, stereo calculations...



Biorthogonal separable wavelets

Let $\varphi, \psi, \tilde{\varphi}$ and $\tilde{\psi}$ be a two dual pairs of scaling functions and wavelets that generate a biorthogonal wavelet basis of $L^2(\mathbb{R})$.

The dual wavelets of ψ^1, ψ^2 and ψ^3 are

$$\tilde{\psi}^1(x, y) = \tilde{\varphi}(x) \tilde{\psi}(y)$$

$$\tilde{\psi}^2(x, y) = \tilde{\psi}(x) \tilde{\varphi}(y)$$

$$\tilde{\psi}^3(x, y) = \tilde{\psi}(x) \tilde{\psi}(y)$$

One can verify that

$$\left\{ \psi_{j,n}^1, \psi_{j,n}^2, \psi_{j,n}^3 \right\}_{j,n \in \mathbb{Z}^3}$$

and

$$\left\{ \tilde{\psi}_{j,n,m}^1, \tilde{\psi}_{j,n,m}^2, \tilde{\psi}_{j,n,m}^3 \right\}_{j,n,m \in \mathbb{Z}^3}$$

are biorthogonal Riesz basis of $L^2(\mathbb{R}^2)$

$$\psi_{j,n,m}^k(x, y) = \frac{1}{2^j} \psi^k\left(\frac{x - 2^j n}{2^j}, \frac{y - 2^j m}{2^j}\right)$$

Fast 2D Wavelet Transform

$$a_j[n, m] = \langle f, \varphi_{j,n,m} \rangle$$

Approximation at scale j

$$d_j^k[n, m] = \langle f, \psi_{j,n,m}^k \rangle$$

Details at scale j

$$k = 1, 2, 3$$

$$[a_J, \{d_j^1, d_j^2, d_j^3\}_{1 \leq j \leq J}]$$

Wavelet representation

Analysis

$$a_{j+1}[n, m] = a_j * \bar{h}\bar{h}[2n, 2m]$$

$$d_{j+1}^1[n, m] = a_j * \bar{h}\bar{g}[2n, 2m]$$

$$d_{j+1}^2[n, m] = a_j * \bar{g}\bar{h}[2n, 2m]$$

$$d_{j+1}^3[n, m] = a_j * \bar{g}\bar{g}[2n, 2m]$$

Synthesis

$$a_j[n, m] = \check{a}_{j+1} * hh[n, m] + \check{d}_{j+1}^1 * hg[n, m] + \check{d}_{j+1}^2 * gh[n, m] + \check{d}_{j+1}^3 * gg[n, m]$$

Fast 2D DWT

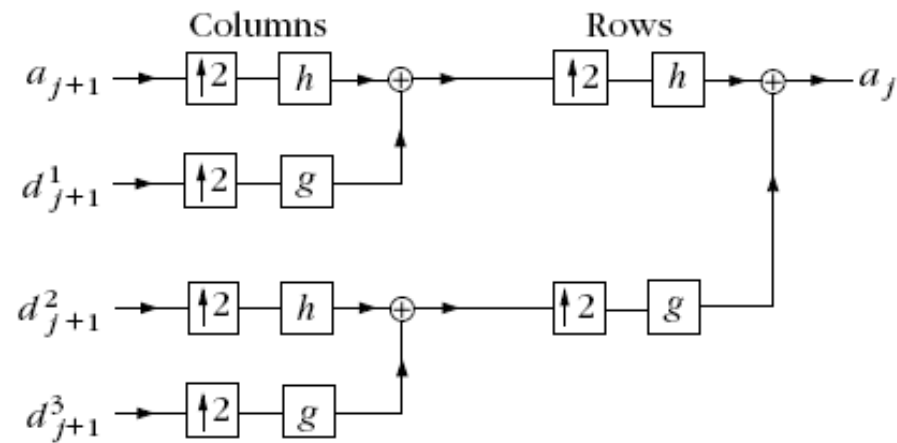
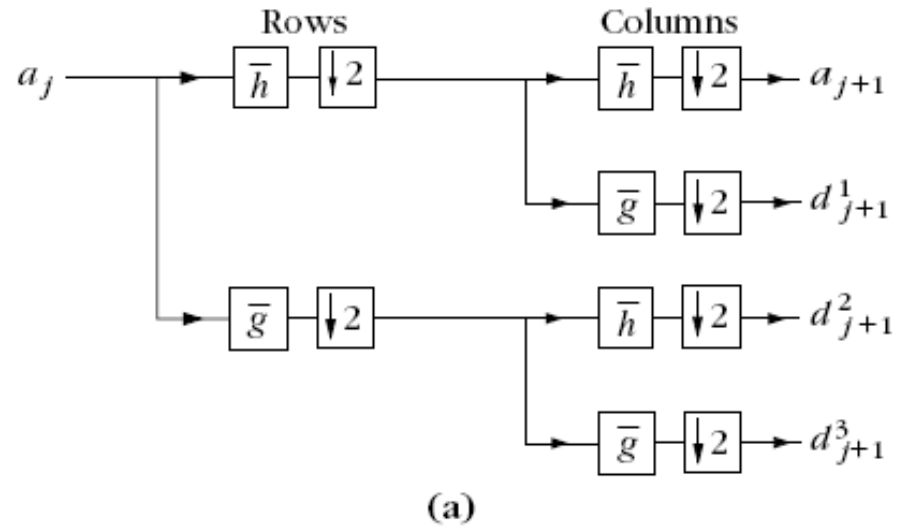

Finite images and complexity

- When a_L is a finite image of $N=N_1 \times N_2$ pixels, we face boundary problems when computing the convolutions
 - A suitable processing at boundaries must be chosen
- For square images with $N_1 N_2$, the resulting images a_j and $d_{k,j}$ have $N_1 N_2 / 2^{2j}$ samples. Thus, *the images of the wavelet representation include a total of N samples.*
 - If h and g have size K , one can verify that $2K/2^{2(j-1)}$ multiplications and additions are needed to compute the four convolutions
 - Thus, the wavelet representation is calculated with fewer than **$8/3 KN^2$ operations.**
 - The reconstruction of a_L by factoring the reconstruction equation requires the same number of operations.

Separable biorthogonal bases

- One-dimensional biorthogonal wavelet bases are extended to separable biorthogonal bases of $L^2(\mathbb{R}^2)$ following the same approach used for orthogonal bases
- Let $\varphi, \psi, \tilde{\varphi}, \tilde{\psi}$ be two dual pairs of scaling functions and wavelets that generate biorthogonal wavelet bases of $L^2(\mathbb{R})$. The dual wavelets of

$$\psi^1(x, y), \psi^2(x, y), \psi^3(x, y)$$

are

$$\tilde{\psi}^1(x, y) = \tilde{\varphi}(x) \tilde{\psi}(y)$$

$$\tilde{\psi}^2(x, y) = \tilde{\varphi}(y) \tilde{\psi}(x)$$

$$\tilde{\psi}^3(x, y) = \tilde{\psi}(x) \tilde{\psi}(x)$$

Separable biorthogonal bases

- One can verify that

$$\left\{ \psi_{j,n,m}^1, \psi_{j,n,m}^2, \psi_{j,n,m}^3 \right\}_{j,n,m \in \mathbb{Z}^3}$$

$$\left\{ \tilde{\psi}_{j,n,m}^1, \tilde{\psi}_{j,n,m}^2, \tilde{\psi}_{j,n,m}^3 \right\}_{j,n,m \in \mathbb{Z}^3}$$

- are Riesz basis of $L^2(\mathbb{R}^2)$

Example

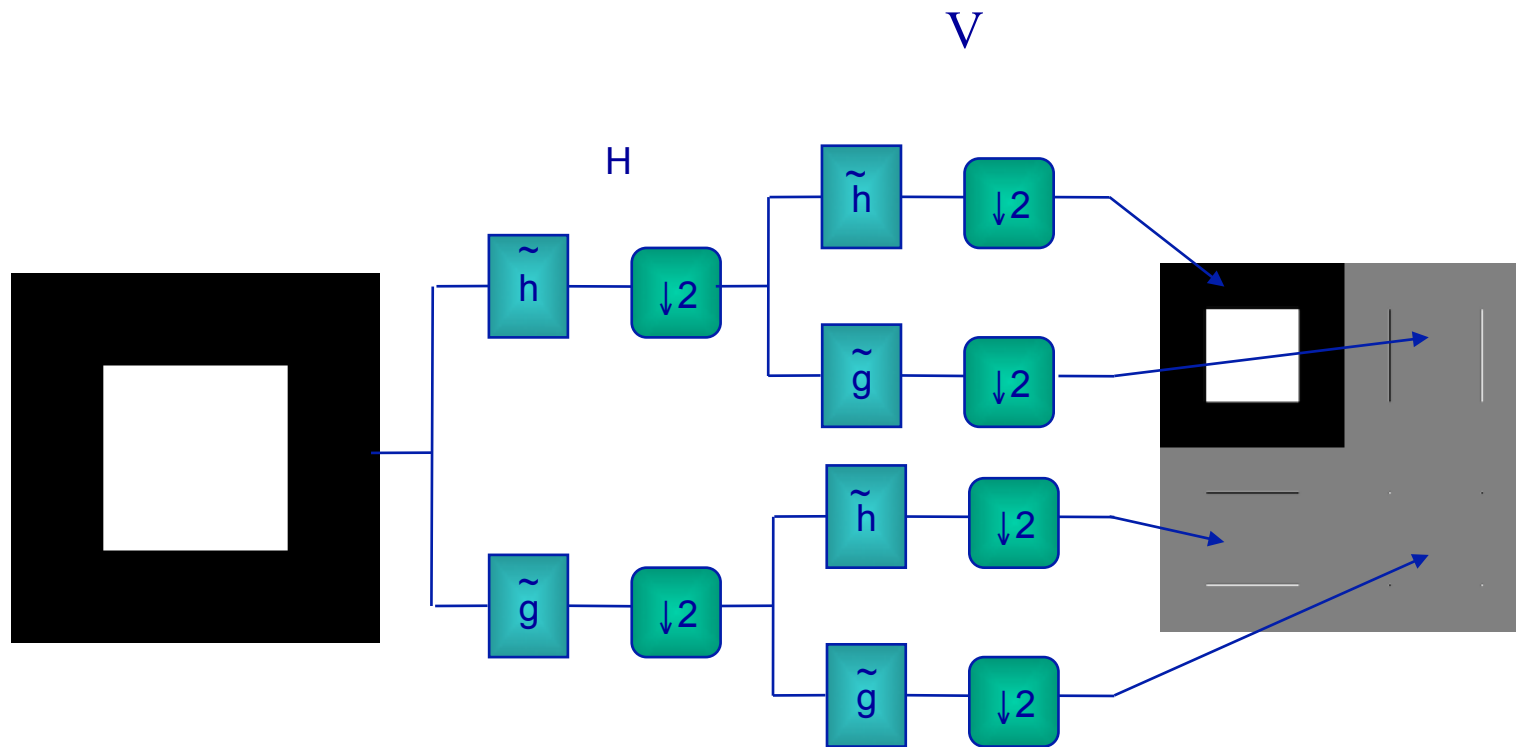

Example

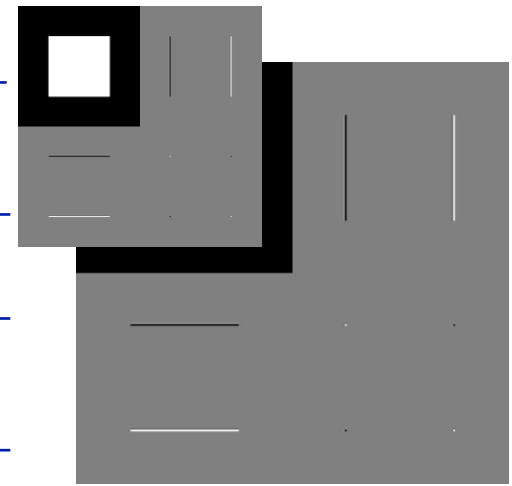
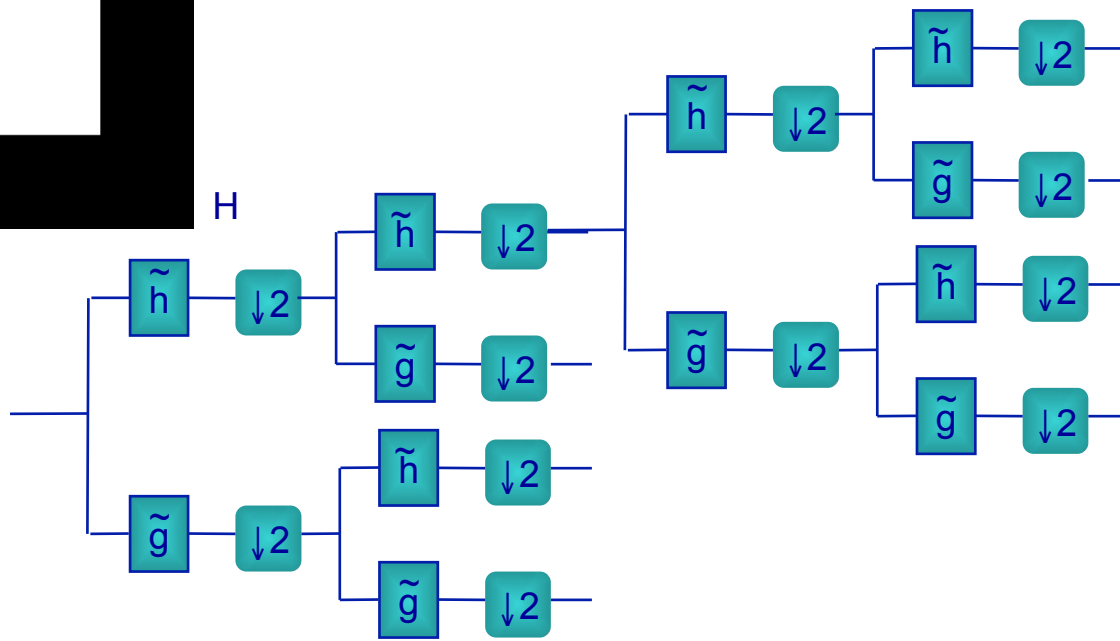
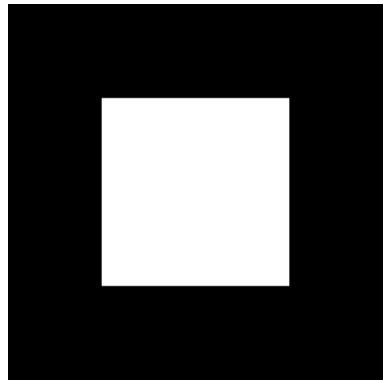

Subband structure for images

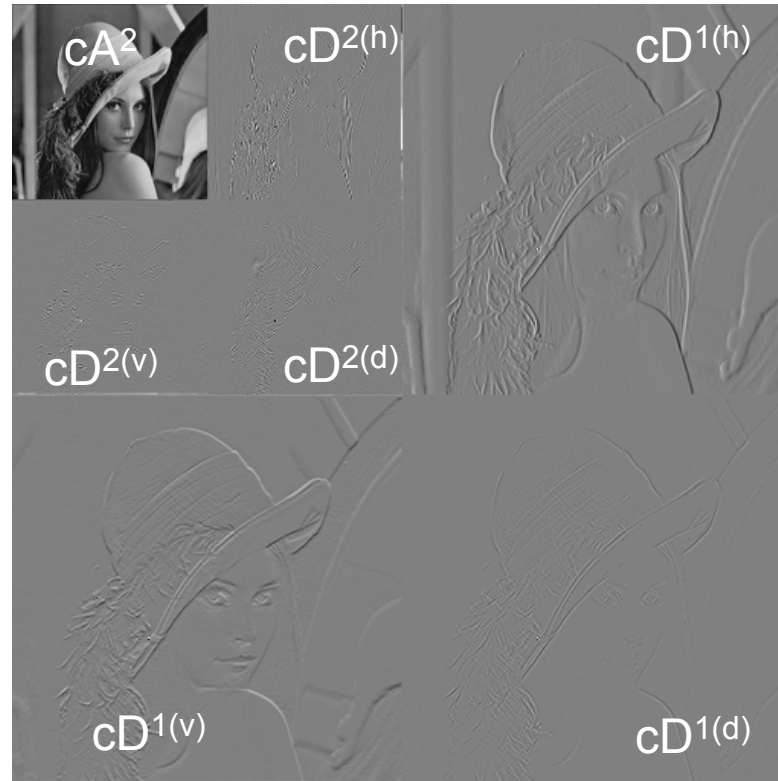
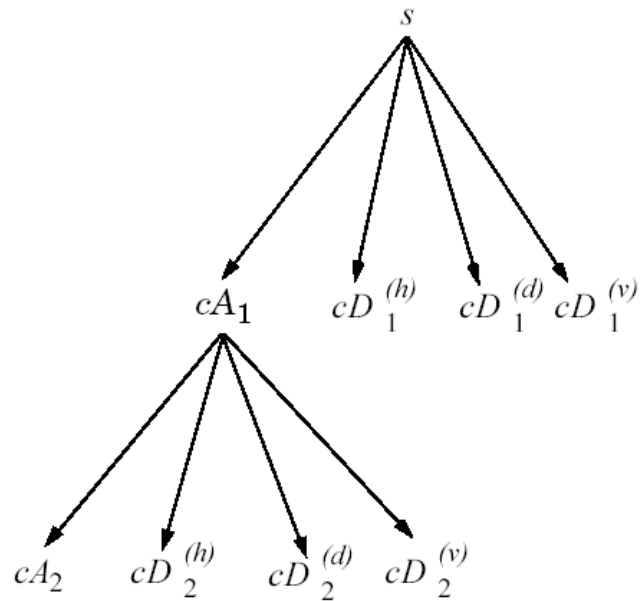

Wavelet bases in higher dimensions

- Separable wavelet orthonormal bases of $L^2(\mathbb{R}^p)$ are constructed for any $p \geq 2$ with a procedure similar to the two-dimensional extension. Let φ be a scaling function and ψ a wavelet that yields an orthogonal basis of $L^2(\mathbb{R})$.
- We denote $\theta^0 = \varphi$ and $\theta^1 = \psi$. To any integer $0 \leq \varepsilon < 2^p$ written in binary form $\varepsilon = \varepsilon_1, \dots, \varepsilon_p$ we associate the p -dimensional functions defined in $x = (x_1, \dots, x_p)$ by

$$\psi^\varepsilon(x) = \vartheta^{\varepsilon_1}(x_1) \dots \vartheta^{\varepsilon_p}(x_p)$$

- For $\varepsilon = 0$ we obtain the p -dimensional scaling function

$$\psi^0(x) = \varphi(x_1) \dots \varphi(x_p)$$

- Non-zero indexes ε correspond to $2^p - 1$ wavelets. At any scale 2^j and for $n = (n_1, \dots, n_p)$ we denote

$$\psi_{j,n}^\varepsilon(x) = \frac{1}{\sqrt{2^{pj}}} \psi^\varepsilon\left(\frac{x_1 - 2^j n_1}{2^j}, \dots, \frac{x_p - 2^j n_p}{2^j}\right)$$

Wavelets in p-dimensions

- Theorem 7.25: The family obtained by dilating and translating the 2^p-1 wavelets for $\varepsilon \neq 0$ is an orthonormal basis of $L^2(\mathbb{R}^p)$

$$\left\{ \psi_{j,n} \right\}_{1 \leq \varepsilon < 2^p, (j,n) \in \mathbb{Z}^{p+1}}$$

- The wavelet coefficients off at scales $2^j > 2^L$ are computed with separable convolutions and subsamplings along the p signal dimensions.

$$a_j[n] = \langle f, \psi_{j,n}^\varepsilon \rangle \text{ for } 0 < \varepsilon < 2^p$$

Fast p-dimensional WT

- The fast WT is calculated with filters that are separable products of the one-dimensional filters h and g .
- The separable p-dimensional low-pass filter is $h_0[n]=h[n_1]..h[n_p]$

Fast p -dimensional WT

Let us denote $u^0[m] = h[m]$ and $u^1[m] = g[m]$. To any integer $\epsilon = \epsilon_1 \dots \epsilon_p$ written in a binary form, we associate a separable p -dimensional band-pass filter

$$g^\epsilon[n] = u^{\epsilon_1}[n_1] \dots u^{\epsilon_p}[n_p].$$

Let $\bar{g}^\epsilon[n] = g^\epsilon[-n]$. One can verify that

$$a_{j+1}[n] = a_j \star \bar{h}^0[2n], \quad (7.268)$$

$$d_{j+1}^\epsilon[n] = a_j \star \bar{g}^\epsilon[2n]. \quad (7.269)$$

We denote by $\check{y}[n]$ the signal obtained by adding a zero between any two samples of $y[n]$ that are adjacent in the p -dimensional lattice $n = (n_1, \dots, n_p)$. It doubles the size of $y[n]$ along each direction. If $y[n]$ has M^p samples, then $\check{y}[n]$ has $(2M)^p$ samples. The reconstruction is performed with

$$a_j[n] = \check{a}_{j+1} \star h^0[n] + \sum_{\epsilon=1}^{2^p-1} \check{d}_{j+1}^\epsilon \star g^\epsilon[n]. \quad (7.270)$$

Fast p-dimensional WT

The 2^p separable convolutions needed to compute a_j and $\{d_j^\epsilon\}_{1 \leq \epsilon \leq 2^p}$ as well as the reconstruction (7.270) can be factored in $2^{p+1} - 2$ groups of one-dimensional convolutions along the rows of p -dimensional signals. This is a generalization of the two-dimensional case, illustrated in Figures 7.27. The wavelet representation of a_L is

$$[\{d_j^\epsilon\}_{1 \leq \epsilon < 2^p, L < j \leq J}, a_j]. \quad (7.271)$$

It is computed by iterating (7.268) and (7.269) for $L \leq j < J$. The reconstruction of a_L is performed with the partial reconstruction (7.270) for $J > j \geq L$.

If a_L is a finite signal of size N^p , the one-dimensional convolutions are modified with one of the three boundary techniques described in Section 7.5. The resulting algorithm computes decomposition coefficients in a separable wavelet basis of $L^2[0, 1]^p$. The signals a_j and d_j^ϵ have 2^{-pj} samples. Like a_L , the wavelet representation (7.271) is composed of N^p samples. If the filter h has K non-zero samples then the separable factorization of (7.268) and (7.269) requires $pK2^{-p(j-1)}$ multiplications and additions. The wavelet representation (7.271) is thus computed with fewer than $p(1 - 2^{-p})^{-1}KN^p$ multiplications and additions. The reconstruction is performed with the same number of operations.

Wavelet bases in higher dimensions

- Theorem 7.25 The family obtained by dilating and translating the 2^p-1 wavelets for ε different from zero

$$\left\{ \psi_{j,n}^{\varepsilon}(x) \right\}_{1 \leq \varepsilon < 2^p, (j,n) \in \mathbb{Z}^{p+1}}$$

is an orthonormal basis for $L^2(\mathbb{R}^p)$.

- 3D DWT

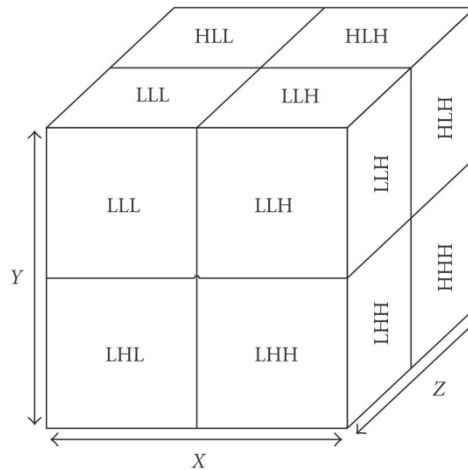

3D DWT

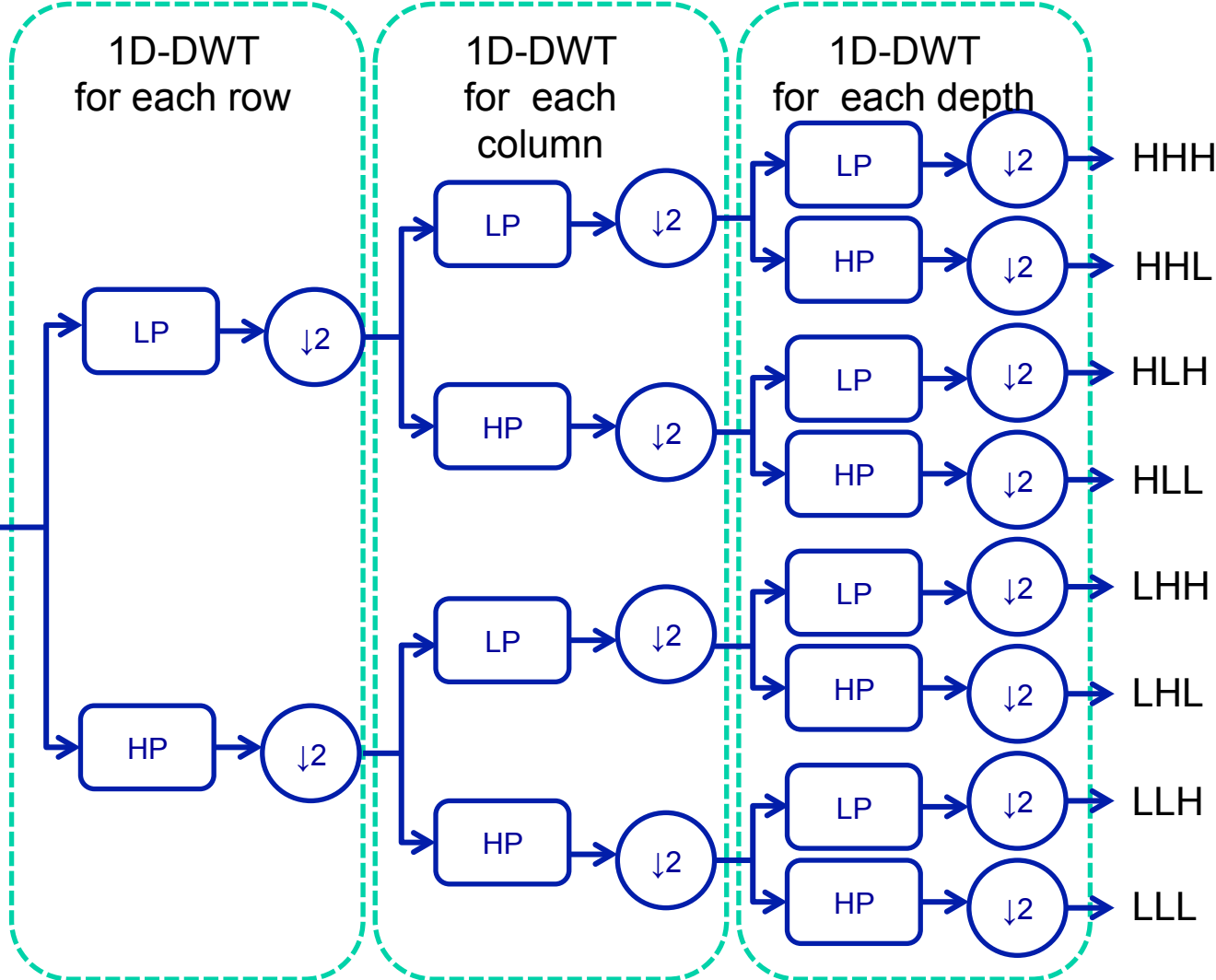

Fig. The filter architecture for 3D wavelet transform

3D wavelets for DSI denoising

DSI
Non-Parametric
Method



Gradient ≥ 200
Time ≥ 15 mins

QBI
Gradient ≥ 60
Time ≥ 10 mins

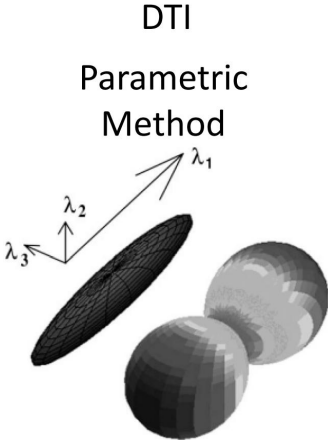
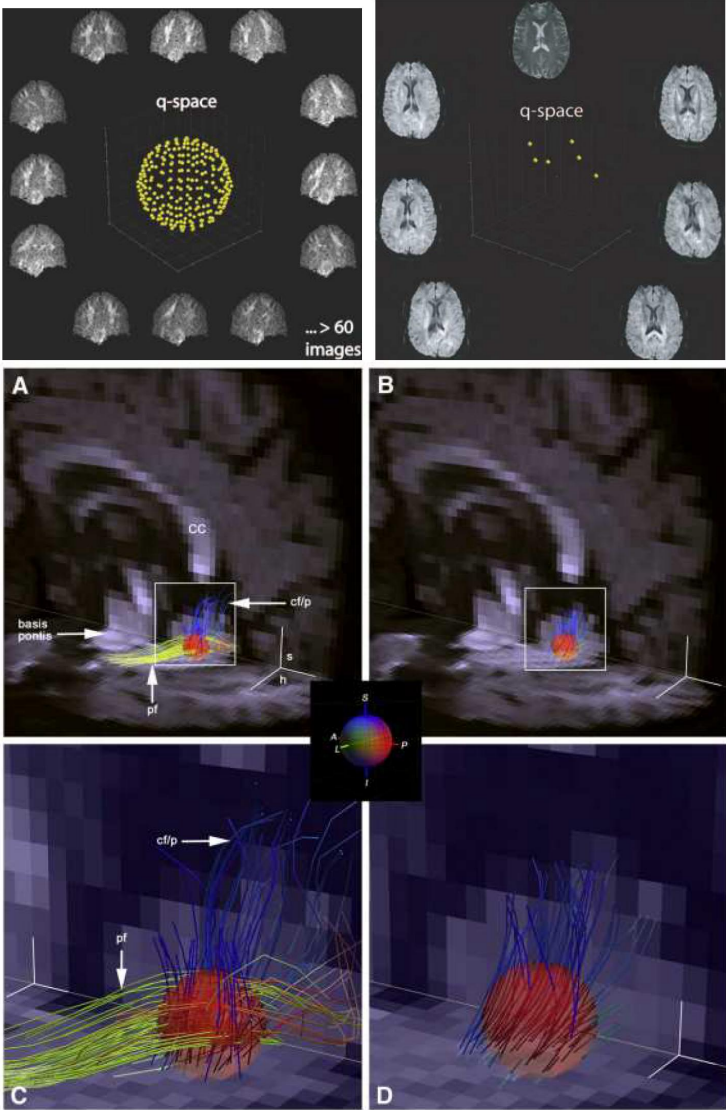

Gradient ≥ 6
Time ≥ 2 mins

(Hagmann et al, 2006)
(Wedeen et al, 2008)

DSI-3D-SWT

METHOD	ACQUISITION	BRIEF DESCRIPTION OF THE ALGORITHM	SPATIAL FILTER
 DSI _{SWT}	cartesian $b \leq 8000$ 257 samples	Multi-resolution approach based on 3D Stationary Wavelet Transform (3D-SWT) to de-noise the propagator reconstructed with DSI	none

